

rulmek

RULMAN MEKATRONİK HIRDAVAT SAN. ve DIŐ TİC. LTD. ŐTİ.

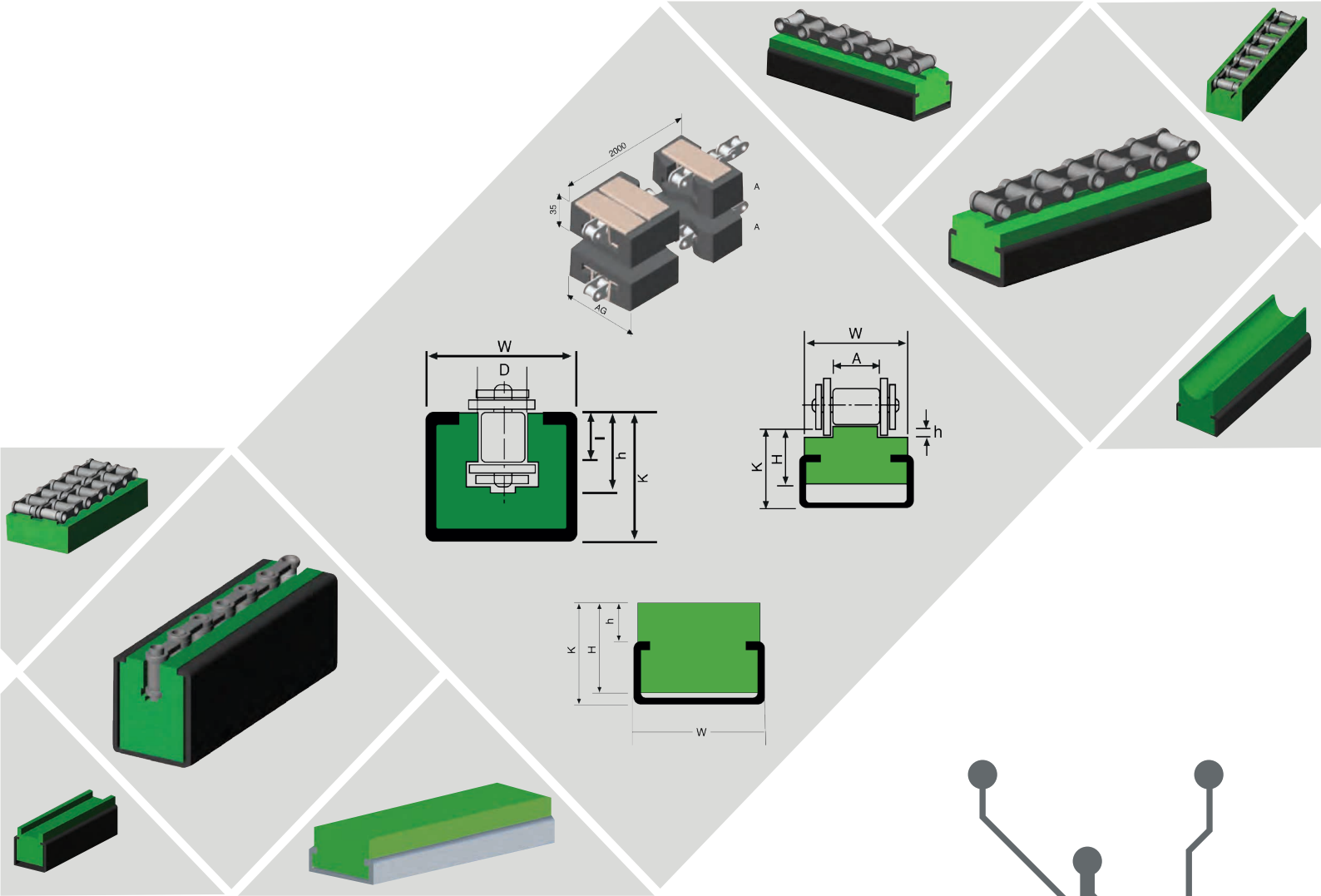

Farklı mekanik ihtiyaçlarınız için
çözüm ortağınız

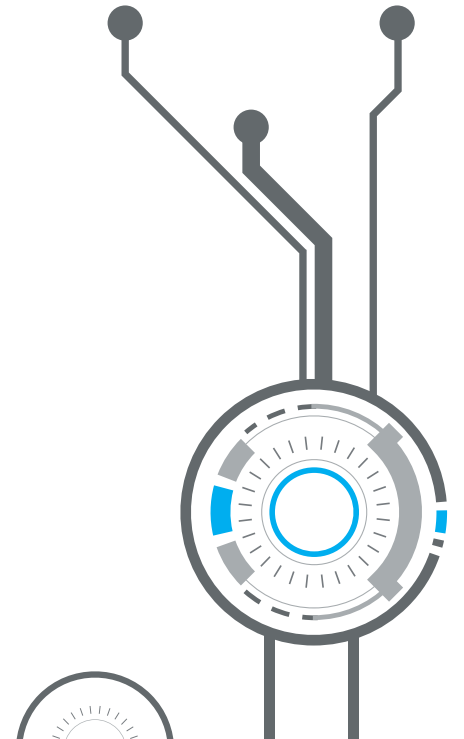

İndeks İçindekiler

Yenilikçi
Çözümler

Gelişmiş
Sistem

Zincir Kızakları Grubu	3-30
Rulman Grubu	31-32
Sızdırmazlık Grubu	33
Dişli Grubu	34
V Kasnak - Kör Kasnak - Kaplin Grubu	35
Zincir - Kayış Grubu	36

PNömatik - Teker Grubu	37
El Aletleri Grubu	38
Müendislik Plastikleri - Metal Grubu	39
Tezgah Tamponu - Bakalit Grubu	40
Zenweld Kaynak Makinası	

Lazer Makinası - Ayakkabı Eldiven Grubu	41
İş Güvenlik	

MARKALAR



HIWIN



Continental
CONTITECH



BOSCH



ASKAYNAK



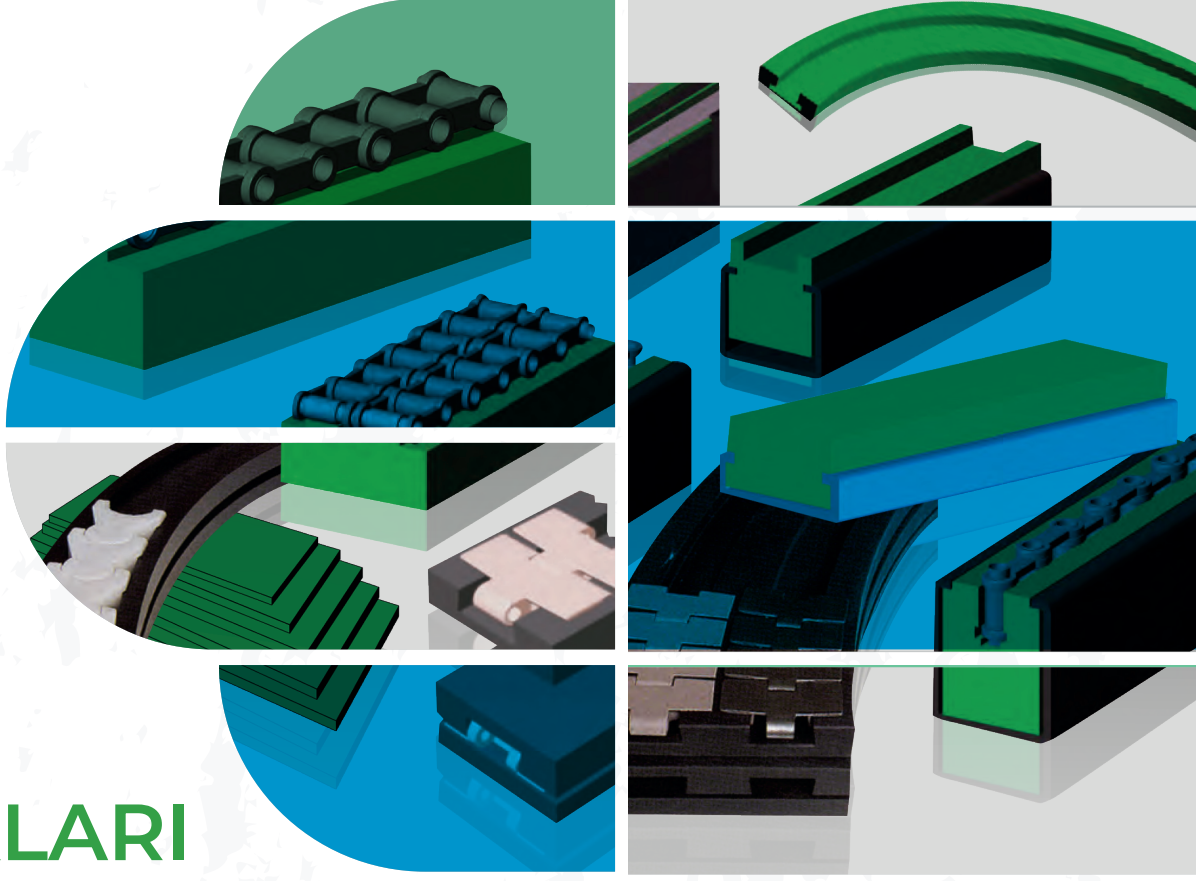

ZİNCİR KIZAKLARI GRUBU



1. Yük Taşıma Kapasitesi

Zincir kızakları, ağır yükleri taşıyabilme kapasiteleri ile bilinir. Zincirlerin sağlam yapısı ve güçlendirilmiş tasarımı, büyük ve ağır yüklerin güvenli bir şekilde hareket ettirilmesini sağlar. Bu özellik, özellikle büyük fabrikalar ve madencilik alanları gibi yüksek kapasiteli taşıma ihtiyaçlarına sahip yerlerde önemli bir avantajdır.

2. Dayanıklılık ve Uzun Ömür

Zincir kızakları, metal zincirlerin ve kızak sisteminin dayanıklılığı sayesinde uzun ömürlüdür. Metal zincirler, aşınma, yıpranma ve diğer dış etkenlere karşı direnç gösterir. Bu dayanıklılık, bakım gereksinimlerini ve işletme maliyetlerini azaltır.

3. Sürekli Hareket ve Verimlilik

Zincir kızakları, sürekli hareketi sağlayan tasarımları ile yüksek verimlilik sunar. Özellikle sürekli üretim süreçlerinde veya sürekli malzeme taşıma gereksinimlerinde, zincir kızakları sorunsuz ve kesintisiz bir operasyon sağlar.

4. Kolay Bakım ve Onarım

Zincir kızaklarının bakım ve onarımı genellikle basittir. Zincirler ve kızaklar, standart parçalardan oluşur ve değiştirilmesi gereken parçalar genellikle hızlı bir şekilde temin edilebilir. Düzenli bakım ile sistemin performansı yüksek tutulabilir.

5. Esneklik ve Uygulama Alanları

Zincir kızakları, çeşitli tasarım ve konfigürasyon seçenekleri sunarak farklı uygulama ihtiyaçlarına göre uyarlanabilir. Düz, eğimli veya döner kızak sistemleri gibi farklı tasarımlar, zincir kızaklarının çeşitli endüstriyel uygulamalarda kullanılmasını sağlar.

6. Güvenlik Özellikleri

Zincir kızakları genellikle güvenlik önlemleriyle donatılmıştır. Yüklerin güvenli bir şekilde taşınmasını sağlamak için fren sistemleri, aşırı yük koruma mekanizmaları ve güvenlik kilitleri gibi özellikler bulunabilir.

7. Enerji Verimliliği

Gelişmiş zincir kızak sistemleri, enerji verimliliği açısından optimize edilebilir. Doğru tasarım ve bakım ile enerji tüketimi en aza indirilebilir, bu da operasyon maliyetlerini düşürür.

8. İnşaat ve Montaj Kolaylığı

Zincir kızaklarının inşaatı ve montajı genellikle kolaydır. Bu sistemler modüler bileşenlerden oluşur ve standart montaj prosedürleri ile kurulabilir. Bu da hem zaman hem de iş gücü tasarrufu sağlar.

Zincir kızakları, endüstriyel taşımacılıkta güçlü ve güvenilir bir çözüm sunar. Dayanıklılığı, yüksek taşıma kapasiteleri ve çeşitli uygulama alanları, onları çeşitli sektörlerde vazgeçilmez bir ekipman haline getirir.

Z PROFİL P 1000

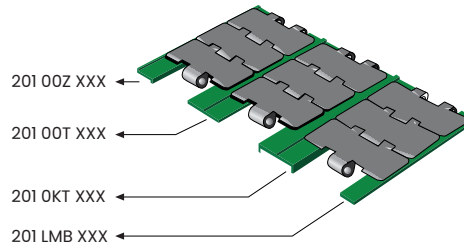
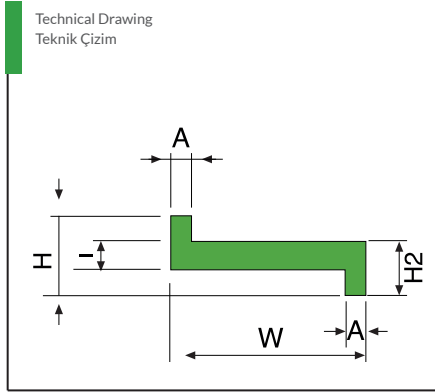

L: Standart Uzunluk (metre)/Standart Length (meter)

	W	A	H	I	H2	L	Kg/m	Stok Kod Stock Code
P 1000 Yeşil/Green	20	2	5,5	3	5,5	50	0,7	201 00Z 003
P 1000 Siyah/Black								201 00Z 002
P 1000 Yeşil/Green	23	3	7	4	7			201 00Z 005
P 1000 Siyah/Black								201 00Z 004

GEÇMELİ Z PROFİL P 1000

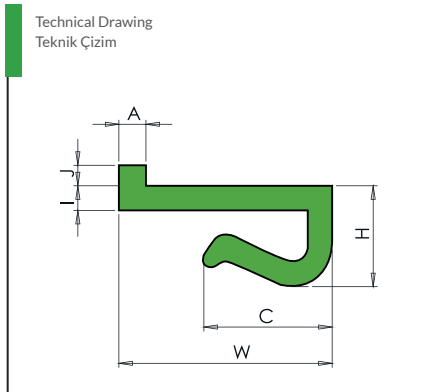

L: Standart Uzunluk (metre)/Standart Length (meter)

	W	A	H	I	J	C	L	Kg/m	Stok Kod Stock Code
P 1000 Yeşil/Green	21	2,5	9	3	2,5	13	50	0,12	201 OGZ 001
P 1000 Siyah/Black									201 OGZ 003
P 1000 Yeşil/Green	25							201 OGZ 002	
P 1000 Siyah/Black								201 OGZ 004	

GEÇMELİ LAMA PROFİL P 1000

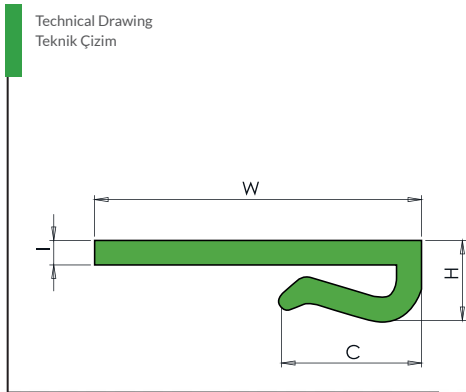

L: Standart Uzunluk (metre)/Standart Length (meter)

	W	H	I	C	L	Kg/m	Stok Kod Stock Code
P 1000 Yeşil/Green	P21	10,6	3	13	50	0,11	201 GLA 100
P 1000 Siyah/Black							201 GLA 101
P 1000 Yeşil/Green	10,2			201 GLA 102			
P 1000 Siyah/Black				201 GLA 103			
P 1000 Yeşil/Green	P25	10,5		20		0,12	201 GLA 104
P 1000 Siyah/Black							201 GLA 105
P 1000 Yeşil/Green	P40	11,5		13		0,18	201 GLA 106
P 1000 Siyah/Black							201 GLA 107
P 1000 Yeşil/Green	10,3		20	0,16	201 GLA 108		
P 1000 Siyah/Black					201 GLA 109		

Kullanılacak Profil 1,5-3 mm kalınlığındadır.
Wearstrip to be used with plate width of 1,5 to 3mm

PROFİL P 1000

Technical Drawing
Teknik Çizim

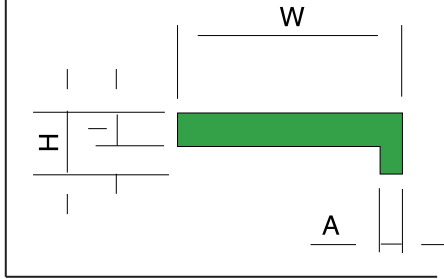

L: Standart Uzunluk (metre)/Standart Length (meter)							
	W	A	H	I	L	Kg/m	Stok Kod Stock Code
P 1000 Yeşil/Green	20	2	5,5	3	60	0,06	201 OOL 001
P 1000 Siyah/Black			6				201 OOL 002
P 1000 Yeşil/Green	53	5	12	5		0,16	201 OOL 003
	35	10	15			0,15	201 OOL 013
	30	10	15			0,14	201 OOL 014
	40	10	15		0,16	201 OOL 015	

L/600 PROFİL P 1000

Technical Drawing
Teknik Çizim

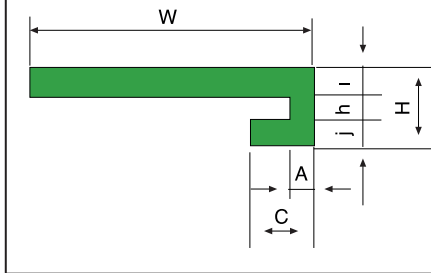

L: Standart Uzunluk (metre)/Standart Length (meter)										
	W	A	H	I	L	C	H	J	Kg/m	Stok Kod Stock Code
P 1000 Yeşil/Green	40	10	8	3	2	25	3	2	0,19	201 OTL 001
P 1000 Siyah/Black										8
P 1000 Yeşil/Green	35	3	10	3,6		11	3	3	0,11	201 OTL 003
P 1000 Siyah/Black										8
P 1000 Yeşil/Green	23	3	10	4		10	8,5	2,5	0,19	201 OTL 005
P 1000 Siyah/Black										11
P 1000 Yeşil/Green	45	4	14	3		10	8,5	2,5	0,19	201 OTL 007
P 1000 Siyah/Black										10

P 1000 SÜRTÜNME PROFİLLERİ

Technical Drawing
Teknik Çizim

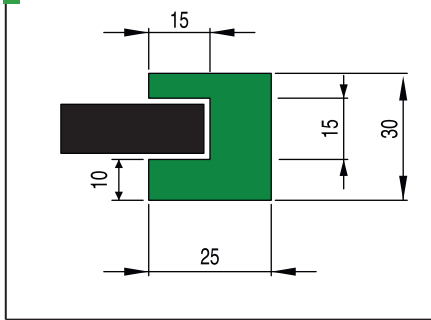

200 DON 001

Technical Drawing
Teknik Çizim

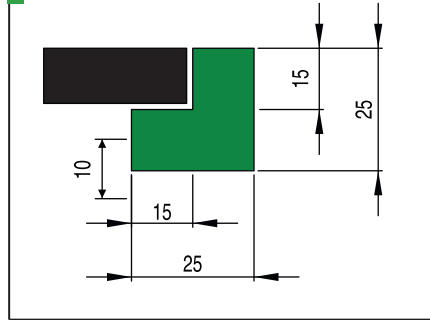

200 DON 002

Technical Drawing
Teknik Çizim

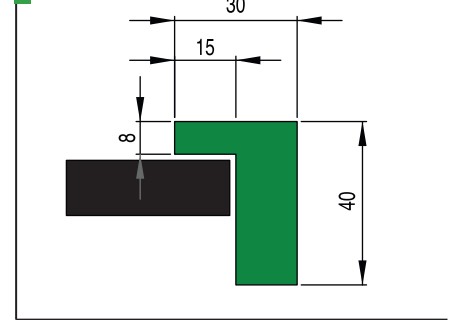

200 DON 003

L: Standart Uzunluk (metre)/Standart Length (meter)			
	L	Kg/m	Stok Kod Stock Code
P 1000 Yeşil/Green	2	0,75	200 DON 001
	2	0,64	200 DON 002
	2	0,68	200 DON 003

T PROFİL P 1000

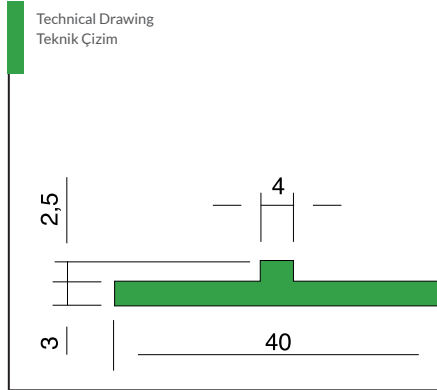

L: Standart Uzunluk (metre)/Standart Length (meter)			
	L	Kg/m	Stok Kod Stock Code
P 1000 Yeşil/Green	50	0,11	201 OTL 003
P 1000 Siyah/Black			201 OTL 004

TCA PROFİL P 1000

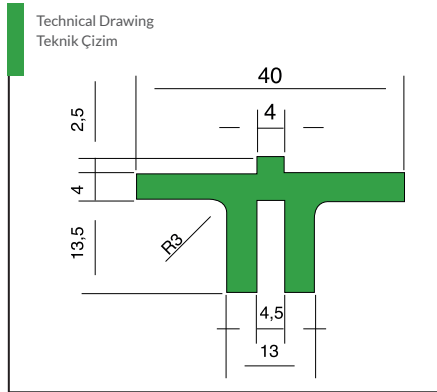

L: Standart Uzunluk (metre)/Standart Length (meter)			
	L	Kg/m	Stok Kod Stock Code
P 1000 Yeşil/Green	2	0,30	201 UOT 001
p 1000 Siyah/Black			201 UOT 002

TCAL PROFİL P 1000

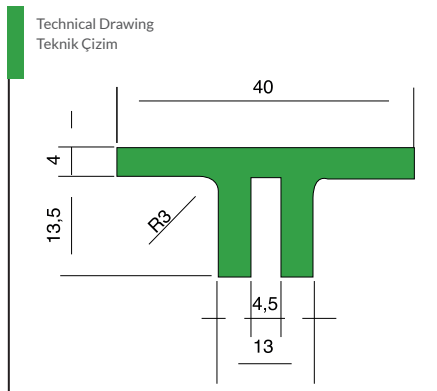

L: Standart Uzunluk (metre)/Standart Length (meter)			
	L	Kg/m	Stok Kod Stock Code
P 1000 Yeşil/Green	2	0,29	201 DOT 001
P 1000 Siyah/Black			201 DOT 002

P 1000 ÇELİK PROFİLLİ HCP KIZAKLARI

Technical Drawing
Teknik Çizim

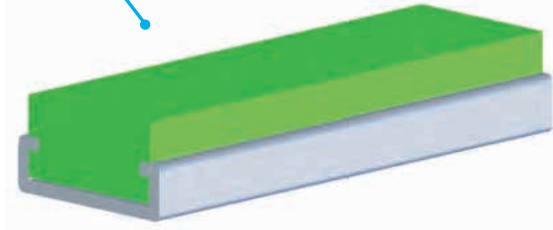
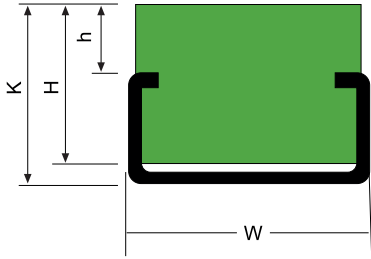

L: Standart Uzunluk (metre)/Standart Length (meter)

	 Kılavuz Guide	W	K	H	h	L	Kg/m	Stok Kod Stock Code	
P 1000 Yeşil/Green	C 2405 ZN	20	6	5	0,8	2	0,350	200 HCC 006	
	C 2405 SS							200 HCP 006	
	C 2405 ZN		11	10	5,8		0,450	200 HCC 011	
	C 2405 SS							200 HCP 011	
	C 2010 ZN	20	14	10	4		0,790	200 HCC 014	
	C 2010 SS							200 HCP 014	
	C 2010 ZN		17	15	7		0,880	200 HCC 017	
	C 2010 SS							200 HCP 017	
	C 2010 ZN	28	22	20	12		0,940	200 HCC 022	
	C 2010 SS							200 HCP 022	
	C 2812 ZN		28	15	10		3	1,180	200 HCC 015
	C 2812 SS								200 HCP 015
	C 2812 ZN	28		18	15		6	1,320	200 HCC 018
	C 2812 SS								200 HCP 018
	C 2812 ZN	38	24	20	12		1,488	200 HCC 024	
	C 2812 SS							200 HCP 024	
	C 3818 ZN		38	22	12		4	2,200	200 HCC 122
	C 3818 SS								200 HCP 122
	C 3818 ZN	38		24	15		6	2,460	200 HCC 124
	C 3818 SS								200 HCP 124
C 3818 ZN	60	30	20	12	2,690	200 HCC 030			
C 3818 SS						200 HCP 030			
C 6020 ZN	60	30	20	10	3,260	200 HCC 130			
C 6020 SS						200 HCP 130			

P 1000 "C" SÜRTÜNME PROFİLLERİ

Technical Drawing
Teknik Çizim

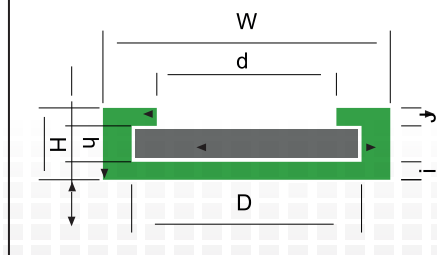

L: Standart Uzunluk (metre)/Standart Length (meter)

	W	H	i	h	J	D	d	L	Kg/m	Stok Kod Stock Code
P 1000 Yeşil/Green	30	12	3,5	5,2	3,3	20,5	12	2	0,17	200 CC3 012
	40	10	3,5	3,5	3	30,5	23	50	0,19	200 CC4 010
	50	10,5	3	4,5	3	28,5	28,5	50	0,24	200 CC5 015
	50	14	3	8,3	2,7	41	30	2	0,26	200 CC5 014
	50	16	3	10,3	2,7	41	30	2	0,27	200 CC5 016
	60	12	3	6,5	2,5	51	35	50	0,28	200 CC6 012

KULAKLI T PROFİL P 1000

Technical Drawing
Teknik Çizim

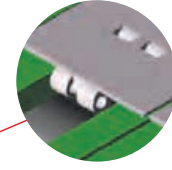
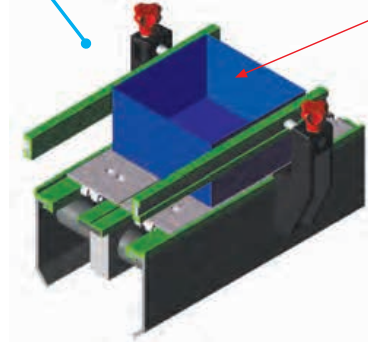
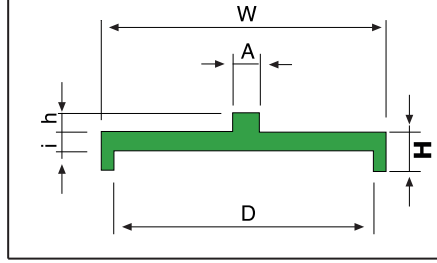

L: Standart Uzunluk (metre)/Standart Length (meter)

	Açıklama Characteristic	W	D	H	i	h	A	L	Kg/m	Stok Kod Stock Code
P 1000 Yeşil/Green	DZ/36	40	36	9	3	3	4	50	0,13	201 OKT 401
P 1000 Siyah/Black										201 OKT 402
P 1000 Yeşil/Green	DZ/31	43	31	15	4	3	0,21		201 OKT 431	
P 1000 Siyah/Black									201 OKT 432	
P 1000 Yeşil/Green	DZ/32	44	32	8	3	2,5	4		0,16	201 OKT 441
P 1000 Siyah/Black										201 OKT 442
P 1000 Yeşil/Green	DZ/41	46	41	11,5	3	4	4		0,17	201 OKT 461
P 1000 Siyah/Black										201 OKT 462

P 1000 "C" SÜRTÜNME PROFİLLERİ

Technical Drawing
Teknik Çizim

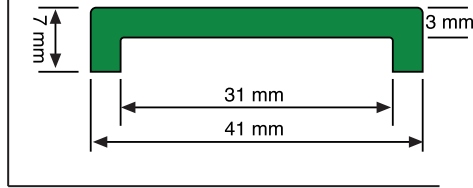

L: Standart Uzunluk (metre)/Standart Length (meter)

	L	Kg/m	Stok Kod Stock Code
P 1000 Yeşil/Green	2	0,170	201 YD2 001
P 1000 Siyah/Black			201 YD2 002

U/630 PROFİL P 1000

Technical Drawing
Teknik Çizim

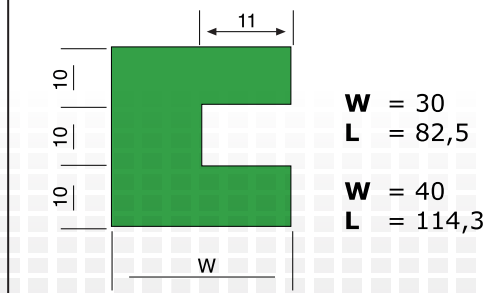

L: Standart Uzunluk (metre)/Standart Length (meter)

	W	L	Kg/m	Stok Kod Stock Code
P 1000 Yeşil/Green	30	2	0,70	201 YU1 001
P 1000 Siyah/Black				201 YU1 002

U/640 PROFİL P 1000

Technical Drawing
Teknik Çizim

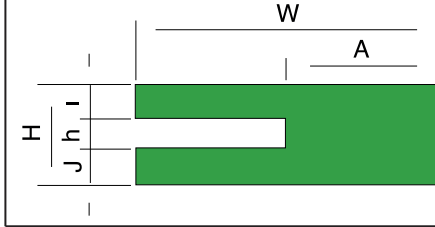

L: Standart Uzunluk (metre)/Standart Length (meter)									Stok Kod Stock Code
	W	H	A	l	h	J	L	Kg/m	
P 1000 Yeşil/Green	30	10	15	3,5	3	3,5	2	0,25	201 YU2 001
P 1000 Siyah/Black									201 YU2 002

P 1000 T MODEL ZİNCİR KIZAKLARI

Technical Drawing
Teknik Çizim

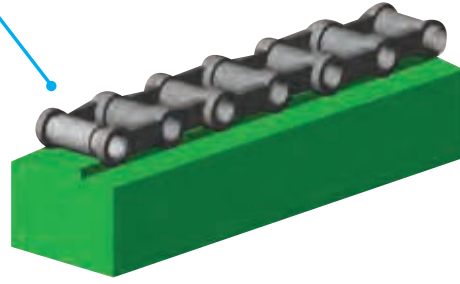
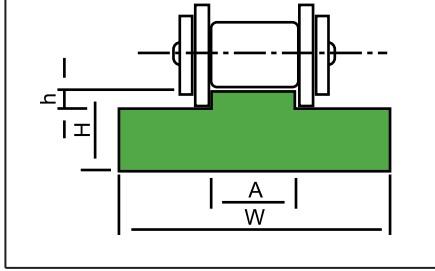

L: Standart Uzunluk (metre)/Standart Length (meter)									
	ISO	Hatve Pitch	W	H	A	h	L	Kg/m	Stok Kod Stock Code
P 1000 Yeşil/Siyah	06 B1	3/8"	15	10	5,4	1,5	2	0,135	200 OTO 038
	08 B1	1/2"	20	10	7,4	2,2		0,165	200 OTO 012
	08 B1	1/2"	20	15	7,4	2,2		0,265	200 OTO 112
	10 B1	5/8"	20	10	9,2	2,6		0,160	200 OTO 058
	10 B1	5/8"	20	15	9,2	2,6		0,260	200 OTO 158
	12 B1	3/4"	25	10	11,3	2,4		0,210	200 OTO 034
	12 B1	3/4"	25	15	11,3	2,4		0,325	200 OTO 134
	16 B1	1"	40	15	16,5	3,5		0,470	200 OTO 100
	16 B1	1"	40	20	16,5	3,5		0,660	200 OTO 101
	20 B1	1 1/4"	45	15	19,0	4,3		0,530	200 OTO 114
	20 B1	1 1/4"	45	20	19,0	4,3		0,720	200 OTO 214
	24 B1	1 1/2"	60	15	24,6	5,6		0,785	200 OTO 412
	28 B1	1 3/4"	75	20	30	6,9		1,130	200 OTO 434
	32 B1	2"	85	20	30	7,8		1,210	200 OTO 200

P 1000 KANALLI TMODEL ZİNCİR KIZAKLARI

Technical Drawing
Teknik Çizim

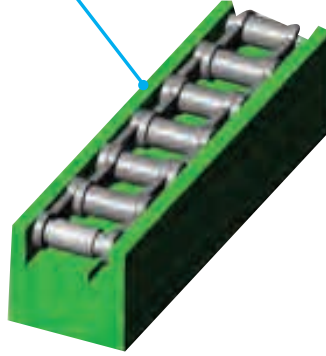
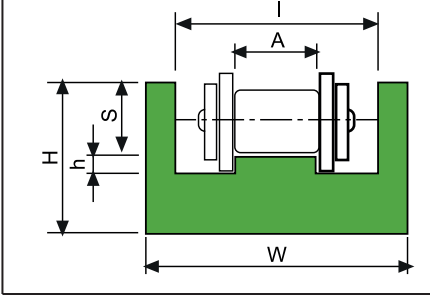

L: Standart Uzunluk (metre)/Standart Length (meter)

	ISO	Hatve Pitch	W	H	I	h	A	S	L	Kg/m	Stok Kod Stock Code
P 1000 Yeşil/Siyah	06 B1	3/8"	25	10	15	1,5	5,4	4,4	2	0,170	200 OT2 038
	08 B1	1/2"	30	15	20	2,2	7,4	7,2		0,275	200 OT2 012
	10 B1	5/8"	33	20	23	2,6	9,2	9,5		0,405	200 OT2 058
	12 B1	3/4"	38	20	28	2,4	11,3	11,1		0,410	200 OT2 034
	16 B1	1"	51	25	41	3,5	16,5	16,5		0,510	200 OT2 100
	20 B1	1 1/4"	56	30	46	4,3	19	20,7		0,720	200 OT2 114

P 1000 2T MODEL HAFİF TİP ZİNCİR KIZAKLARI

Technical Drawing
Teknik Çizim

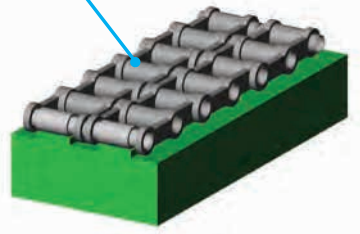
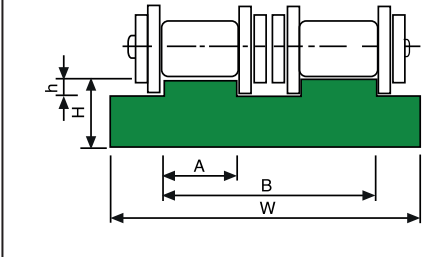

L: Standart Uzunluk (metre)/Standart Length (meter)

	ISO	Tipi Type	Hatve Pitch	W	H	A	h	B	L	Kg/m	Stok Kod Stock Code	
P 1000 Yeşil/Siyah	06 B2	Hafif Tip Light Type	3/8"	25	10	5,4	1,5	16	2	0,230	200 TH2 510	
	08 B2		1/2"	35		7,4	2,2	21		0,306	200 TH3 510	
	10 B2		5/8"	40	9,2	15	9,2	2,6		26	0,344	200 TH4 010
			5/8"		0,524		200 TH4 015					
	12 B2		3/4"	45	11,3	15	11,3	2,4		31	0,396	200 TH4 510
			3/4"		0,598		200 TH4 515					

P 1000 2T MODEL AĞIR TİP ZİNCİR KIZAKLARI

Technical Drawing
Teknik Çizim

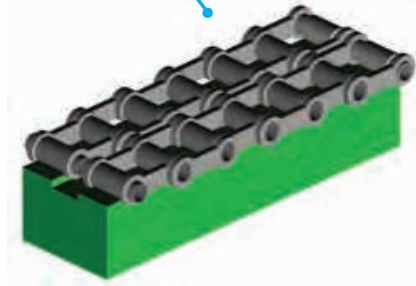
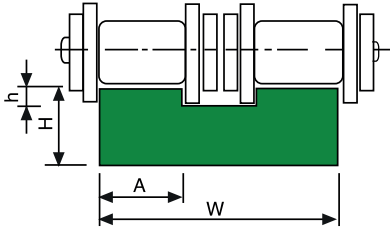

L: Standart Uzunluk (metre)/Standart Length (meter)

	ISO	Tipi Type	Hatve Pitch	W	H	A	h	B	L	Kg/m	Stok Kod Stock Code
P 1000 Yeşil/Siyah	16 B2	Ağır Tip Heavy Type	1"	48	15	16,5	3,5	-	2	0,863	200 TA4 815
					20		3,5			1,156	200 TA4 820
	15		4,3	0,912	200 TA5 515						
	20		4,3	1,232	200 TA5 520						
			24 B2	1 1/2"	72	24,6	5,6			1,499	200 TA7 220
			28 B2	1 3/4"	89	30	6,9			1,790	200 TA8 920
			32 B2	2"	89	7,8	1,750			200 TA8 921	

"TT" ZİNCİR KIZAKLARI

Technical Drawing
Teknik Çizim

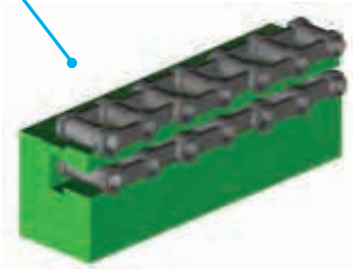
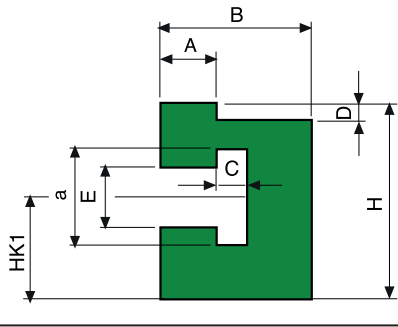

L: Standart Uzunluk (metre)/Standart Length (meter)

	Hatve Pitch	a	A	C	D	E	B	H	Hq	HK1	Stok Kod Stock Code
P 1000 Yeşil/Siyah	3/8"	9,5	5,4	4,6	1,5	6,6	20,0	24,4	26,9	14,5	200 OTT 001
	1/2"	13,0	7,4	5,4	2,2	8,6	20,0	26,9	29,4	15,5	200 OTT 002
	5/8"	15,5	9,2	5,6	2,6	10,4	20,0	33,8	36,2	18,5	200 OTT 003
	3/4"	17,0	11,3	6,4	2,6	12,2	28,0	37,3	40,3	21,5	200 OTT 004
	1/1"	22,0	16,5	10,5	4,2	16,0	38,0	50,5	54,0	31,5	200 OTT 005

P 1000 3 SIRALI ZİNCİR KIZAKLARI

Technical Drawing
Teknik Çizim

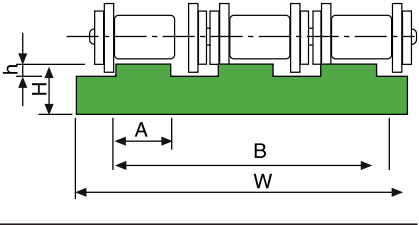

Technical Drawing
Teknik Çizim

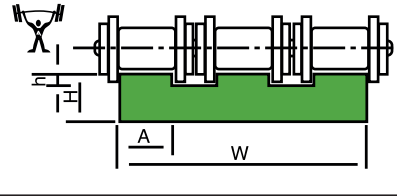

L: Standart Uzunluk (metre)/Standart Length (meter)

	ISO	Hatve Pitch	W	H	A	h	B	L	Kg/m	Stok Kod Stock Code
P 1000 Yeşil/Siyah	06 B3	3/8"	35	10	5,4	1,5	25,9	2	0,306	200 B33 510
	08 B3	1/2"	45	10	7,4	2,2	35,3		0,381	200 B34 510
	08 B3	1/2"	45	15	7,4	2,2	35,3		0,595	200 B34 515
	08 B3	1/2"	45	20	7,4	2,2	35,3		0,808	200 B34 520
	10 B3	5/8"	55	10	9,2	2,6	42,5		0,455	200 B35 510
	12 B3	3/4"	65	10	11,3	2,4	50,3		0,546	200 B36 510
	16 B3	1"	95	15	16,5	3,5	80,3		1,167	200 B39 515
	20 B3	1 1/4"	92	15	19,0	4,3	92,0		1,304	200 B39 215
	24 B3	1 1/2"	121	20	24,6	5,6	121,5		2,247	200 B31 120
	28 B3	1 3/4"	149	25	30,0	6,9	149,3		3,522	200 B31 925
32 B3	2"	149	30	30,0	7,8	149,3	4,262	200 B31 930		

P 1000 "UCD" ZİNCİR KIZAKLARI

Technical Drawing
Teknik Çizim

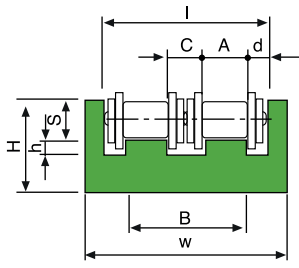

L: Standart Uzunluk (metre)/Standart Length (meter)

	ISO	Hatve Pitch	W	H	I	h	A	S	B	C	d	L	Kg/m	Stok Kod Stock Code
P 1000 Yeşil/Siyah	06 B2	3/8"	36	15	26	1,5	5,4	4,4	16	5,2	5	2	0,390	200 UCD 036
	08 B2	1/2"	45	20	35	2,2	7,4	7,2	21	6,2	7		0,620	200 UCD 045
	10 B2	5/8"	50	25	40	2,6	9,2	9,5	26	7,6	7		0,816	200 UCD 050
	12 B2	3/4"	56	25	46	2,4	11,3	11,1	31	8,4	7,5		0,810	200 UCD 056
	16 B2	1"	85	30	75	3,5	16,5	16,5	48,4	15,4	13,3		1,200	200 UCD 085

P 1000 "UCC" ZİNCİR KIZAKLARI

Technical Drawing
Teknik Çizim

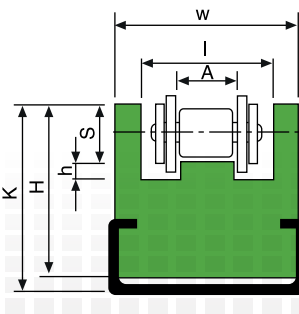

L: Standart Uzunluk (metre)/Standart Length (meter)

	ISO	Hatve Pitch	Kılavuz Guide	W	H	K	I	h	A	S	L	Kg/m	Stok Kod Stock Code
P 1000 Yeşil/Siyah	06 B1	3/8"	C 2010 ZN	25	15	18	15	1,5	5,4	4,4	2	0,760	200 UCC C25
	06 B1	3/8"	C 2010 SS	25	15	18	15	1,5	5,4	4,4		0,760	200 UCC P25
	08 B1	1/2"	C 2812 SS	30	25	27	20	2,2	7,4	7,2		1,100	200 UCC C30
	08 B1	1/2"	C 2812 ZN	30	25	27	20	2,2	7,4	7,2		1,100	200 UCC P30
	10 B1	5/8"	C 2812 ZN	33	30	32	23	2,6	9,2	9,5		1,305	200 UCC C33
	10 B1	5/8"	C 2812 SS	33	30	32	23	2,6	9,2	9,5		1,305	200 UCC P33
	12 B1	3/4"	C 3818 ZN	38	35	40	28	2,4	11,3	11,1		2,335	200 UCC C38
	12 B1	3/4"	C 3818 SS	38	35	40	28	2,4	11,3	11,1		2,335	200 UCC P38
	16 B1	1"	C 3818 ZN	51	40	45	41	3,5	16,5	16,5		2,440	200 UCC C51
	16 B1	1"	C 3818 SS	51	40	45	41	3,5	16,5	16,5		2,440	200 UCC P51

P 1000 "TCG" ZİNCİR KIZAKLARI

Technical Drawing
Teknik Çizim

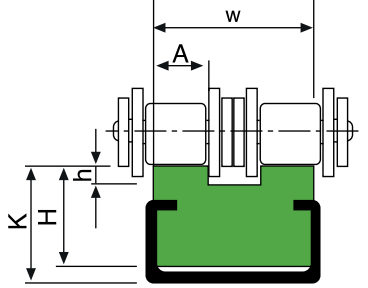

L: Standart Uzunluk (metre)/Standart Length (meter)

	ISO	Hatve Pitch	Kılavuz Guide	W	H	K	h	A	L	Kg/m	Stok Kod Stock Code
P 1000 Yeşil/Siyah	06 B2	3/8"	C 2010 ZN	15,6	10	15	1,5	5,4	2	0,615	200 TCG C38
			C 2010 SS								200 TCG P38
	08 B2	1/2"	C 2010 ZN	21,5	15	18	2,2	7,4			200 TCG C12
			C 2010 SS								200 TCG P12
	10 B2	5/8"	C 2812 ZN	26,0	15	18	2,6	9,2			200 TCG C58
			C 2812 SS								200 TCG P58
	12 B2	3/4"	C 2812 ZN	31,0	15	18	2,4	11,3			200 TCG C34
			C 2812 SS								200 TCG P34

P 1000 "TT" MODEL TİPİ ZİNCİR KIZAKLARI

Technical Drawing
Teknik Çizim

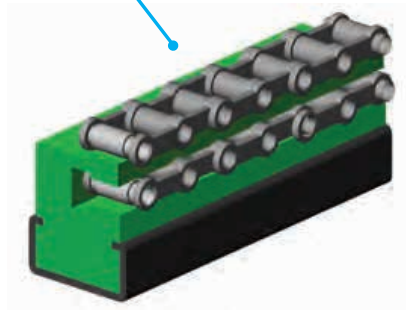
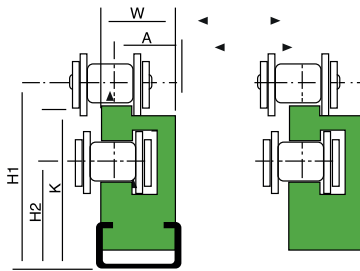

L: Standart Uzunluk (metre)/Standart Length (meter)

	ISO	Hatve Pitch	Kılavuz Guide	W	H	H1	H2	A	K	L	Kg/m	Stok Kod Stock Code
P 1000 Yeşil/Siyah	06 B1	3/8"	C 2010 ZN	20	25	30	17	14,5	27	2	0,900	200 ITT C38
			C 2010 SS									200 ITT P38
	08 B1	1/2"	C 2010 ZN	20	28	34	18	16,5	30		0,950	200 ITT C12
			C 2010 SS									200 ITT P12
	10 B1	5/8"	C 2010 ZN	20	33	41	21	15,5	36		1,120	200 ITT C58
			C 2010 SS									200 ITT P58
	12 B1	3/4"	C 2812 ZN	28	37	46,5	24	18,6	41		1,700	200 ITT C34
			C 2812 SS									200 ITT P34
	16 B1	1"	C 3818 ZN	38	51	62	34	25	54		3,100	200 ITT C01
			C 3818 SS									200 ITT P01

Zincir Kızakları Grubu

P 1000 CC MODEL TİPİ ZİNCİR KIZAKLARI

Technical Drawing
Teknik Çizim

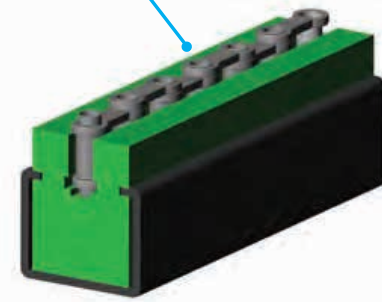
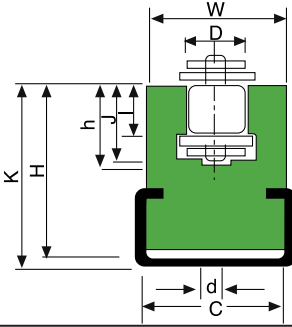

L: Standart Uzunluk (metre)/Standart Length (meter)

	ISO	Hatve Pitch	Kılavuz Guide	W	H	K	I	J	h	d	D	C	L	Kg/m	Stok Kod Stock Code										
P 1000 Yeşil/Siyah	06 B	3/8"	C 2010 ZN	20	17,5	21	5,6	8,7	9,9	4	6,6	9,3	2	0,622	200 ALC 038										
			C 2010 SS												200 ALP 038										
	08 B	1/2"	C 2812 ZN	28	27,5	32	7,6	11,5	12,7	5	8,7	12,8			2	1,450	200 ALC 012								
			C 2812 SS														200 ALP 012								
	10 B	5/8"	C 2812 ZN	28	27,5	32	9,3	13,5	14,8	6	10,4	15,4					2	1,402	200 ALC 058						
			C 2812 SS																200 ALP 058						
	12 B	3/4"	C 3818 ZN	32	34,0	43	11,5	15,9	17,5	7	12,3	16,9							2	1,709	200 ALC 034				
			C 3818 SS																		200 ALP 034				
	16 B	1"	C 3818 ZN	32	40	50	15,9	25,7	28,2	9	16,2	24,4									2	1,600	200 ALC 100		
			C 3818 SS																				200 ALP 100		
	20 B	1 1/4"	C 6020 ZN	32	45	55	19,4	29,3	31,2	11	19,3	27,5											2	4,800	200 ALC 114
			C 6020 SS																						200 ALP 114
24 B	1 1/2"	C 6020 ZN	32	55	65	25,2	38,2	40,1	16	25,7	36,5	2	5,000	200 ALC 112											
		C 6020 SS												200 ALP 112											
28 B	1 3/4"	C 6020 ZN	32	70	80	30,8	46,9	48,9	17	28,3	41,5			2	6,200	200 ALC 134									
		C 6020 SS														200 ALP 134									
32 B	2"	C 6020 ZN	32	70	80	30,8	47,3	53,0	19	29,6	44,5					2	6,200	200 ALC 200							
		C 6020 SS																200 ALP 200							

P 1000 CCZ MODEL ÇELİK PROFİLLİ ZİNCİR KIZAKLARI

Technical Drawing
Teknik Çizim

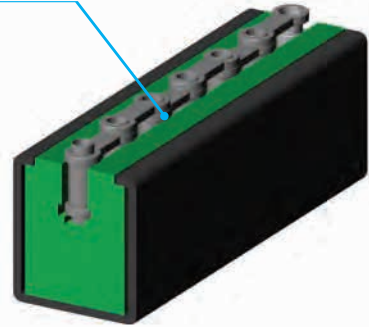
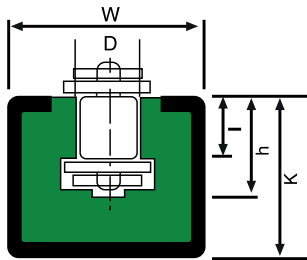

L: Standart Uzunluk (metre)/Standart Length (meter)

	ISO	Hatve Pitch	Kılavuz Guide	W	K	h	I	D	L	Kg/m	Stok Kod Stock Code										
P 1000 Yeşil/Siyah	06 B	3/8"	C 3024 ZN	30	24	10,0	5,6	6,6	2	1,375	200 CCZ 038										
			C 3024 SS			10,0					200 CCZ 138										
	08 B	1/2"	C 3024 ZN	30	24	12,7	7,6	8,7			2	1,350	200 CCZ 012								
			C 3024 SS			12,7							200 CCZ 112								
	08 B	1/2"	C 2816 ZN	28	16	12,7	7,6	8,7					2	1,260	200 CCZ 212						
			C 2816 SS			12,7									200 CCZ 312						
	10 B	5/8"	C 3024 ZN	30	24	14,8	9,3	10,4							2	1,300	200 CCZ 058				
			C 3024 SS			14,8											200 CCZ 158				
	12 B	3/4"	C 3024 ZN	30	24	17,5	11,5	12,3									2	1,260	200 CCZ 034		
			C 3024 SS			17,5													200 CCZ 134		
	16 B	1"	C 4540 ZN	32	40	28,2	15,9	16,2											2	2,930	200 CCZ 100
			C 4540 SS			28,2															200 CCZ 101

P 1000 CCZ MODEL BL TİPİ ZİNCİR KIZAKLARI

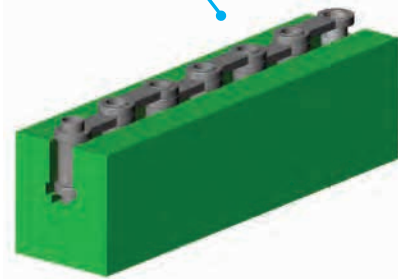
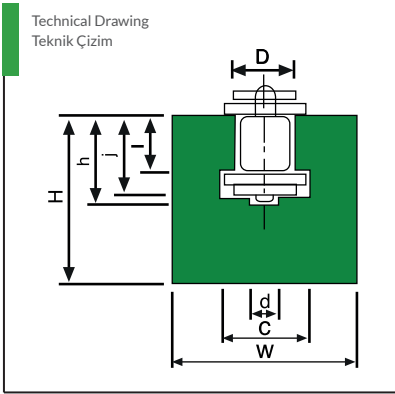

L: Standart Uzunluk (metre)/Standart Length (meter)

	ISO	Hatve Pitch	W	H	C	h	I	D	J	d	L	Kg/m	Stok Kod Stock Code
P 1000 Yeşil/Siyah	06 B	3/8" *7/32"	20	25	9,3	10	5,6	6,6	8,7	4	2	0,414	200 BLO 038
	08 B	1/2" *5/16"	24	30	12,8	12,7	7,6	8,7	11,5	5		0,564	200 BL1 012
	10 B	5/8" *3/8"	30	35	15,4	14,8	9,5	10,4	13,5	6		0,832	200 BL2 058
	12 B	3/4" *7/16"	40	35	16,9	17,5	11,5	12,3	15,9	7		1,106	200 BL3 034
	16 B	1" *17 mm	40	45	24,4	28,2	15,9	16,2	25,7	9		1,231	200 BL4 001
	20 B	1 1/4" *3/4"	50	50	27,5	31,2	19,4	19,3	29,3	11		1,726	200 BL5 114
	24 B	1 1/2" *1"	60	60	36,5	40,1	25,2	25,7	38,2	16		2,332	200 BL6 112
	28 B	1 3/4" *31 mm	70	70	41,5	48,9	30,8	28,3	46,9	17		3,173	200 BL7 134
	32 B	3/8" *7/32"	75	75	44,5	53,0	30,8	29,6	47,3	19		3,264	200 BL8 002

P 1000 U MODEL ÇELİK PROFİLLİ KIZAKLARI

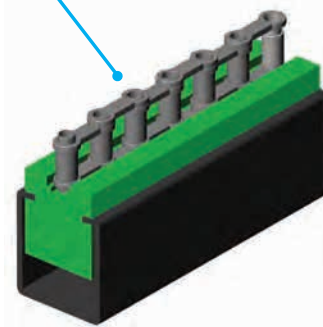
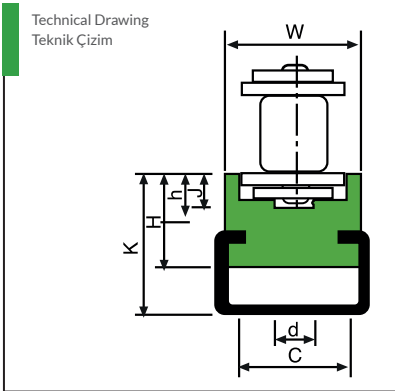

L: Standart Uzunluk (metre)/Standart Length (meter)

	ISO	Hatve Pitch	Kılavuz Guide	W	H	K	h	j	d	L	Kg/m	Stok Kod Stock Code
P 1000 Yeşil/Siyah	06 B1	3/8"	C 2010 ZN	20	10	15	4,2	2,8	2,8	2	0,720	200 CUO C38
			C 2010 SS									200 CUO P38
	08 B1	1/2"	C 2010 ZN	25	15	22	4,8	3,5	3,5		1,140	200 CUO C12
			C 2010 SS									200 CUO P12
	10 B1	5/8"	C 2010 ZN	25	15	22	5,1	3,6	3,6		1,130	200 CUO C58
			C 2010 SS									200 CUO P58
	12 B1	3/4"	C 2812 ZN	35	20	27	5,7	3,9	3,9		1,270	200 CUO C34
			C 2812 SS									200 CUO P34
	16 B1	1"	C 3818 ZN	35	25	33	10	8,4	8,4		2,030	200 CUO C01
			C 3818 SS									200 CUO P01

Zincir Kızakları Grubu

P 1000 U ZİNCİR KIZAKLARI

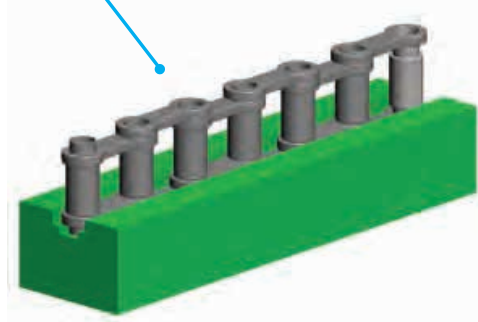
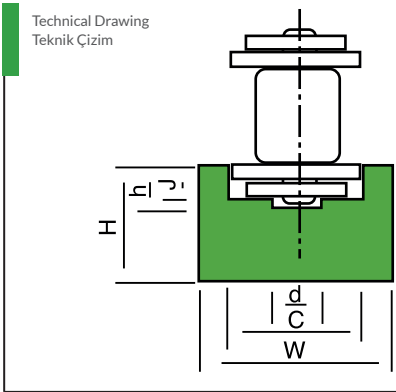

L: Standart Uzunluk (metre)/Standart Length (meter)

	ISO	Hatve Pitch	W	H	C	h	J	d	L	Kg/m	Stok Kod Stock Code
P 1000 Yeşil/Siyah	06 B	3/8" *7/32"	20	15	9,2	4,2	2,8	4	2	0,257	200 OU0 038
	08 B	1/2" *5/16"	25	15	12,7	4,8	3,5	5		0,308	200 OU1 012
	10 B	5/8" *3/8"	25	15	15,2	5,1	3,6	6		0,296	200 OU2 058
	12 B	3/4" *7/16"	25	20	16,7	5,7	3,9	7		0,430	200 OU3 034
	16 B	1" *17 mm	35	25	24,4	10	8,4	9		0,624	200 OU4 001

P 1000 U DÜZ BANTLAR İÇİN ÇELİK PROFİLLİ ZİNCİR KIZAKLARI

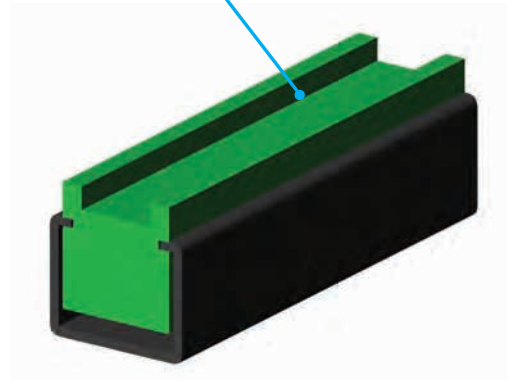
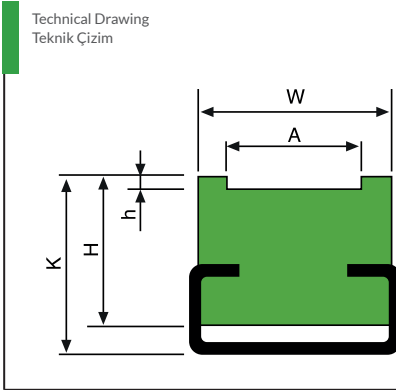

L: Standart Uzunluk (metre)/Standart Length (meter)

	Kılavuz Guide	L	Kg/m	Stok Kod Stock Code
P 1000 Yeşil/Siyah	ZN	2	-	200 TUO 001
	SS			200 TUO 002

K :

H :

h :

W :

A :

*Lütfen ölçüleri doldurarak talepte bulununuz.

P 1000 T MODEL ÇELİK PROFİLLİ ZİNCİR KIZAKLARI

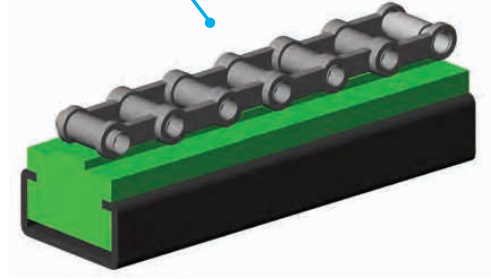
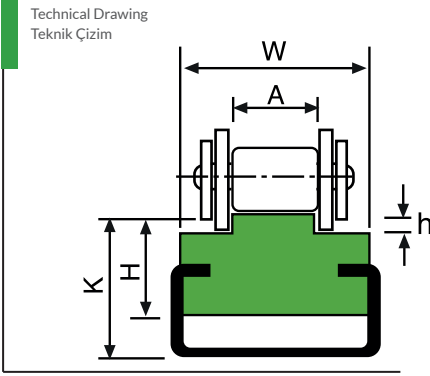

L: Standart Uzunluk (metre)/Standart Length (meter)

	ISO	Hatve Pitch	Kılavuz Guide	W	H	K	h	A	L	Kg/m	Stok Kod Stock Code
P 1000 Yeşil/Siyah	06 B1	3/8"	C 2010 ZN	20	15	17	1,5	5,4	2	0,620	200 H15 038
			C 2010 SS				200 H15 038				
	08 B1	1/2"	C 2010 ZN	17		2,2	7,4	0,695		200 H15 012	
			C 2010 SS			200 H15 012					
	10 B1	5/8"	C 2010 ZN	18	2,6	9,2	0,700	200 H15 058			
			C 2010 SS		200 H15 058						
	12 B1	3/4"	C 2012 ZN	28	20	24	2,4	11,3		1,170	200 H15 034
			C 2012 SS				200 H15 034				
	16 B1	1"	C 2012 ZN	15	18	3,5	16,5	2,245		200 H20 100	
			C 2012 SS							200 H20 101	
	20 B1	1 1/4"	C 2012 ZN	38	25	30	3,5	16,5		1,250	200 H15 100
			C 2012 SS								200 H15 101
	24 B1	1 1/2"	C 3818 ZN	30	4,3	19,0	2,305	200 H25 114			
			C 3818 SS					200 H25 214			
28 B1	1 3/4"	C 3818 ZN	5,6	24,6	2,390	200 H25 112					
		C 3818 SS				200 H25 112					
30 B1	2"	C 3818 ZN	6,9	30	2,410	200 H25 134					
		C 3818 SS				200 H25 234					
32 B1	2"	C 3818 ZN	7,8	30	2,480	200 H25 200					
		C 3818 SS				200 H25 201					

P 1000 ZİNCİR KIZAKLARI

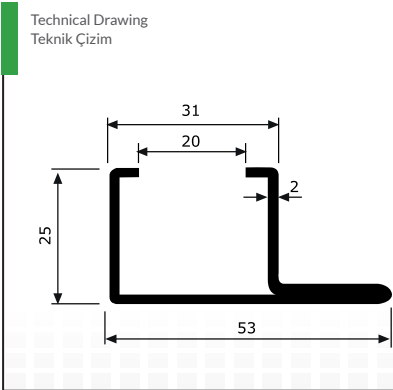

Profil Bölümü/Profiles: "C" L: Standart Uzunluk (metre)/Standart Length (meter)

Kılavuz Guide	L	Kg/m	Stok Kod Stock Code
ZN	2	1,200	200 KDC 001
SS	2	1,200	200 KDP 002

P 1000 ZİNCİR KIZAKLARI

Technical Drawing
Teknik Çizim

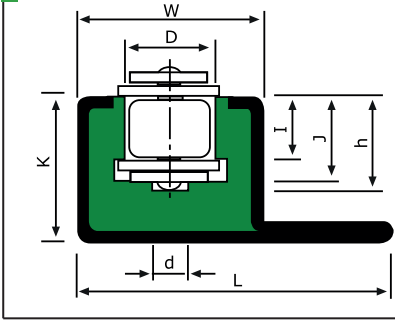

Profil Bölümü/Profiles: "L"

L: Standart Uzunluk (metre)/Standart Length (meter)

	Kılavuz Guide	Hatve Pitch	W	K	L	I	J	h	d	D	L	Kg/m	Stok Kod Stock Code
P 1000 Yeşil/Siyah	ZN	3/8"	31	25	53	5,6	8,7	9,9	4	6,6	2	2,340	200 YDC 038
	SS	3/8"											200 YDP 038
	ZN	1/2"										2,300	200 YDC 012
	SS	1/2"											200 YDP 012
	ZN	5/8"										2,250	200 YDC 058
	SS	5/8"											200 YDP 058
ZN	3/4"	2,250	200 YDC 034										
SS	3/4"		200 YDP 034										

P 1000 ZİNCİR KIZAKLARI

Technical Drawing
Teknik Çizim

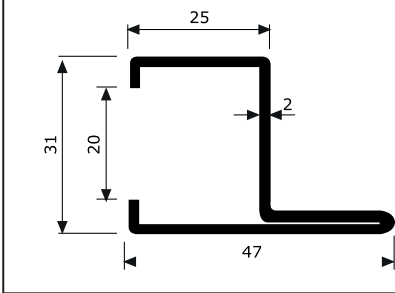

Profil Bölümü/Profiles: "C" L: Standart Uzunluk (metre)/Standart Length (meter)

Kılavuz Guide	L	Kg/m	Stok Kod Stock Code
ZN	2	1,200	200 KDC 003
SS	2	1,200	200 KDP 004

Technical Drawing
Teknik Çizim

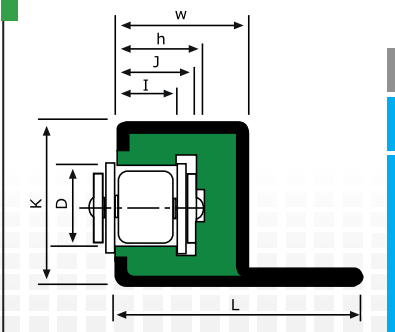

Profil Bölümü/Profiles: "L"

L: Standart Uzunluk (metre)/Standart Length (meter)

	Kılavuz Guide	Hatve Pitch	W	K	L	I	J	h	d	D	L	Kg/m	Stok Kod Stock Code
P 1000 Yeşil/Siyah	ZN	3/8"	31	25	53	5,6	8,7	9,9	4	6,6	2	2,150	200 DYC 038
	SS	3/8"											200 DYP 038
	ZN	1/2"										2,100	200 DYC 012
	SS	1/2"											200 DYP 012
	ZN	5/8"										2,060	200 DYC 058
	SS	5/8"											200 DYP 058
ZN	3/4"	2,060	200 DYC 034										
SS	3/4"		200 DYP 034										

Zincir Kızakları Grubu

P 1000 ÇELİK PROFİLLİ KAYIŞ KLAVUZLARI

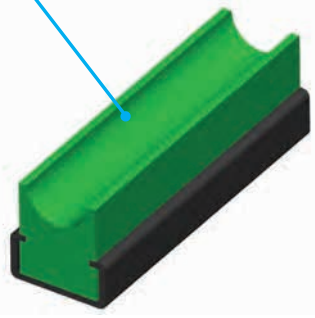
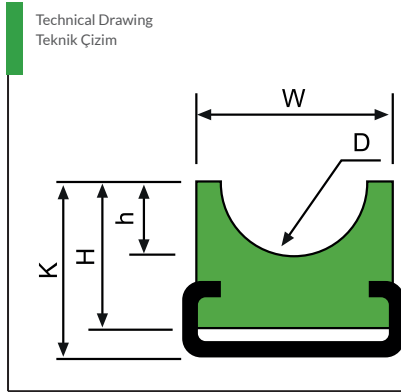

L: Standart Uzunluk (metre)/Standart Length (meter)

	Kılavuz Guide	W	H	h	K	D	L	Kg/m	Stok Kod Stock Code
P 1000 Yeşil/Siyah	C 2010 ZN	20	10	2	14	4	2	0,680	200 CCO 004
	C 2010 SS			5		200 CPO 004			
	C 2010 ZN			2,5		5		200 CCO 005	
	C 2010 SS			3		6		200 CPO 005	
	C 2010 ZN			4		8		200 CCO 006	
	C 2010 SS			6		200 CPO 006			
	C 2010 ZN			8		200 CCO 008			
	C 2010 SS			10		200 CPO 008			
	C 2812 ZN	28	15	5	18	10		1,179	200 CCO 010
	C 2812 SS			12		200 CPO 010			
	C 2812 ZN			6		12		200 CCO 012	
	C 2812 SS			7,5		15		200 CPO 012	
	C 2812 ZN			15		200 CCO 015			
	C 2812 SS			20		200 CPO 015			
C 2812 ZN	24	24	10	20	1,280	200 CCO 020			
C 2812 SS			200 CPO 020						

P 1000 ÇELİK PROFİLLİ "V" KAYIŞ KLAVUZLARI

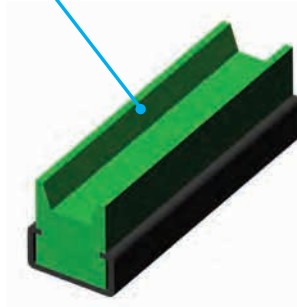
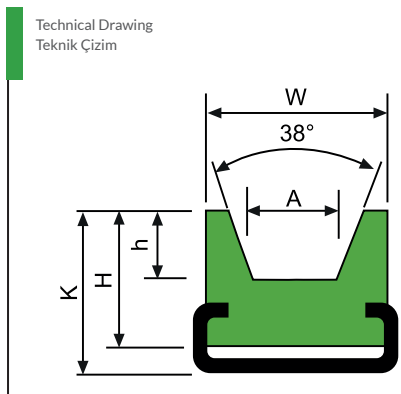

L: Standart Uzunluk (metre)/Standart Length (meter)

	Kılavuz Guide	W	H	h	K	A		L	Kg/m	Stok Kod Stock Code
P 1000 Yeşil/Siyah	C 2010 ZN	20	15	3	17	6,5	10	2	0,787	200 VC0 004
	C 2010 SS									200 VP0 004
	C 2010 ZN			5		8			13	200 VC0 005
	C 2010 SS			6		200 VP0 005				
	C 2812 ZN	25	20	5	24	10	17		1,352	200 VC0 006
	C 2812 SS									200 VP0 006
	C 2812 ZN			8		10,5			20	200 VC0 008
	C 2812 SS			11		200 VP0 008				
	C 3818 ZN	38	25	11	32	13,5	22		2,265	200 VC0 010
	C 3818 SS									200 VP0 010
	C 3818 ZN			19		30			2,574	200 VC0 012
	C 3818 SS			200 VP0 012						

P 1000 "V" KAYIŞ KIZAKLARI

Technical Drawing
Teknik Çizim

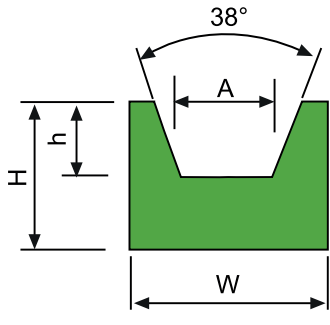

L: Standart Uzunluk (metre)/Standart Length (meter)

	W	H	h	A		L	Kg/m	Stok Kod Stock Code
P 1000 Yeşil/Siyah	20	10	3	6,5	8	2	0,197	200 CTV 020
	20	12	5	8	10		0,232	200 CTV 120
	25	12	5	10	13		0,292	200 CTV 025
	30	15	8	10,5	17		0,429	200 CTV 030
	35	20	11	13,5	20		0,660	200 CTV 035
	40	25	13	19	30		0,944	200 CTV 040

P 1000 "CTO" KAYIŞ KIZAKLARI

Technical Drawing
Teknik Çizim

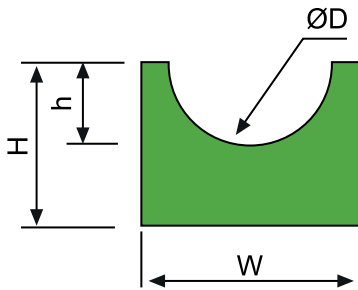

L: Standart Uzunluk (metre)/Standart Length (meter)

	W	H	h	ØD	L	Kg/m	Stok Kod Stock Code
P 1000 Yeşil/Siyah	15	10	4	2	2	0,144	200 CTO 015
			5	2,5		0,140	200 CTO 115
			6	3		0,186	200 CTO 020
	20	12	8	4		0,175	200 CTO 120
			10	5		0,260	200 CTO 025
	25	12	12	6		0,244	200 CTO 125
			15	7,5		0,286	200 CTO 225
			20	10		0,442	200 CTO 030

P 1000 "YD1" KAYIŞ KIZAKLARI

Technical Drawing
Teknik Çizim

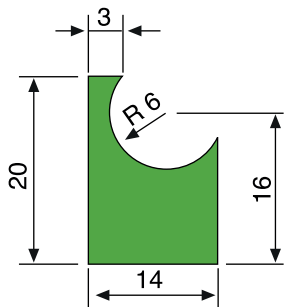

L: Standart Uzunluk (metre)/Standart Length (meter)

	L	Kg/m	Stok Kod Stock Code
P 1000 Yeşil/Siyah	2	0,18	200 CY1 001

P 1000 "YD2" KAYIŞ KIZAKLARI

Technical Drawing
Teknik Çizim

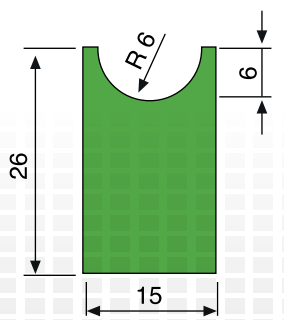

L: Standart Uzunluk (metre)/Standart Length (meter)

	L	Kg/m	Stok Kod Stock Code
P 1000 Yeşil/Siyah	2	0,34	200 CY1 002

P 1000 ÖZEL KAYIŞ KIZAKLARI

Technical Drawing
Teknik Çizim

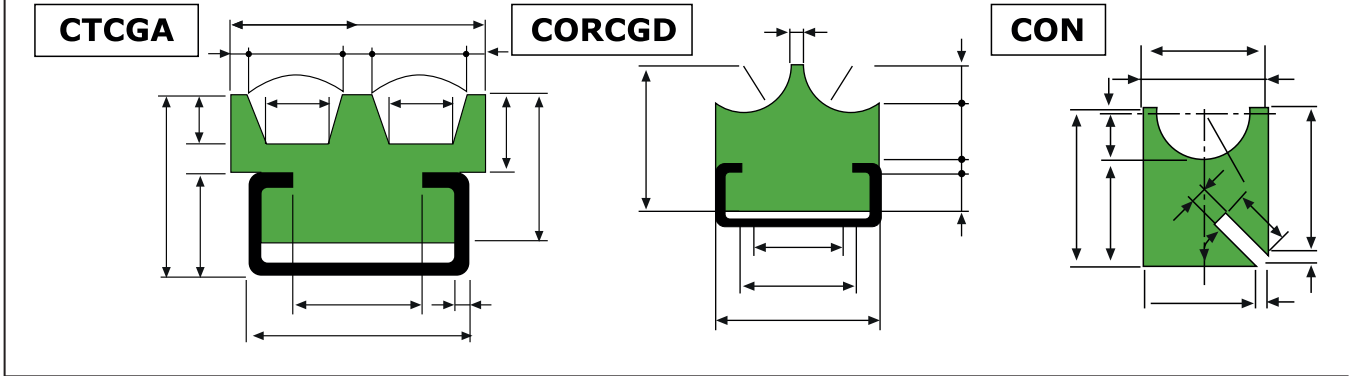

P 1000 "GME" SIRALI ZİNCİR KIZAKLARI

Technical Drawing
Teknik Çizim

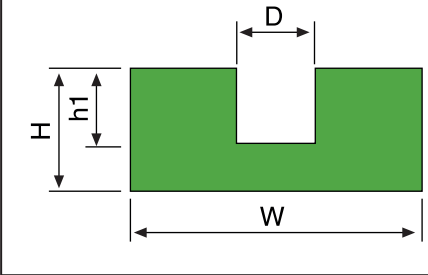

L: Standart Uzunluk (metre)/Standart Length (meter)

	W	H	D	h1	L	Kg/m	Stok Kod Stock Code
P 1000 Yeşil/Siyah	30	15	7	7	2	0,400	200 GME 030
	35	20	9	9		0,610	200 GME 035
	45	25	11	11		1,000	200 GME 045
	55	30	15	15		1,420	200 GME 055

P 1000 "GHE" SIRALI ZİNCİR KIZAKLARI

Technical Drawing
Teknik Çizim

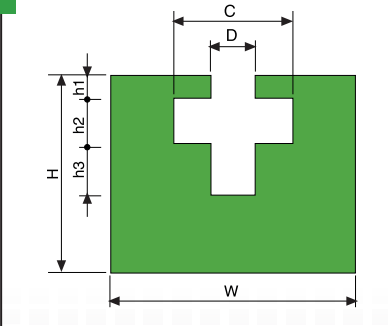

L: Standart Uzunluk (metre)/Standart Length (meter)

	W	H	D	C	h1	h2	h3	L	Kg/m	Stok Kod Stock Code
P 1000 Yeşil/Siyah	45	35	7	23	4,5	7	7	2	1,400	200 GHE 045
	50	40	9	31	5,0	9	9		1,740	200 GHE 050
	50	45	11	35	8,5	11	11		1,700	200 GHE 150
	60	50	15	47	10,5	15	15		2,145	200 GHE 060

P 1000 "GH1" SIRALI ZİNCİR KIZAKLARI

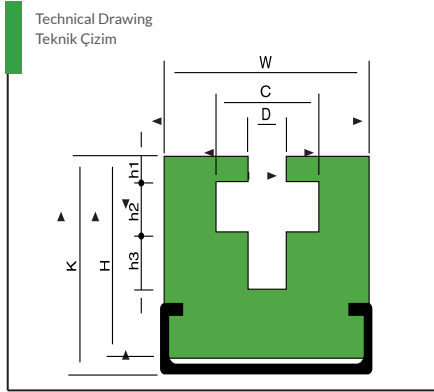

L: Standart Uzunluk (metre)/Standart Length (meter)

	Kılavuz Guide	W	K	D	C	h1	h2	h3	L	Kg/m	Stok Kod Stock Code
P 1000 Yeşil/Siyah	C 3018 ZN	45	45	7	45	4,5	7	8	2	3,200	200 GH1 C45
	C 3018 SS										200 GH1 P45
	C 3018 ZN	50	50	9	50	5,0	9	10		3,800	200 GH1 C50
	C 3018 SS										200 GH1 P50
	C 3018 ZN	50	60	11	60	8,5	11	12		3,900	200 GH1 C51
	C 3018 SS										200 GH1 P51
	C 6020 ZN	60	75	15	75	10,5	15	16		5,100	200 GH1 C60
	C 6020 SS										200 GH1 P60

P 1000 "GH2" SIRALI ZİNCİR KIZAKLARI

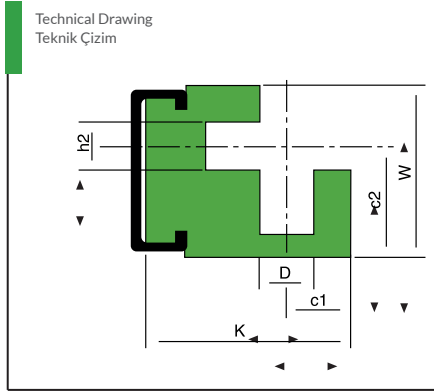

L: Standart Uzunluk (metre)/Standart Length (meter)

	Kılavuz Guide	W	K	D	h2	c1	c2	L	Kg/m	Stok Kod Stock Code
P 1000 Yeşil/Siyah	C 2010 ZN	27	34	7	7	10,5	17,5	2	1,200	200 GH2 C27
	C 2010 SS									200 GH2 P27
	C 2812 ZN	32	42	9	9	12,5	20,5		2,200	200 GH2 C32
	C 2812 SS									200 GH2 P32
	C 3818 ZN	42,5	56	11	11	16,5	25,5		3,200	200 GH2 C42
	C 3818 SS									200 GH2 P42
	C 6020 ZN	60	70	15	15	20,5	33,5		4,100	200 GH2 C60
	C 6020 SS									200 GH2 P60

GEÇMELİ Z PROFİL P 1000

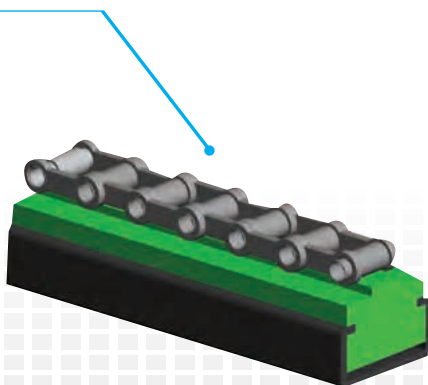
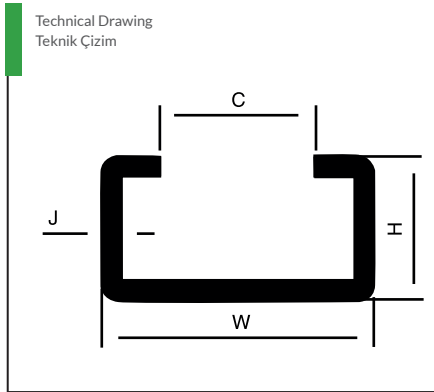

L: Standart Uzunluk (metre)/Standart Length (meter)

Profil Guide	W	H	C	J	L	Kg/m	Stok Kod Stock Code
C 24/05 ZN	24	5,2	17,5	1	2	0,280	201 C02 405
C 24/05 SS							201 P02 405
C 20/10 ZN	20	10	10	1,5		0,490	201 C02 010
C 20/10 SS							201 P02 010
C 28/12 ZN	28	12	14	2		0,860	201 C02 812
C 28/12 SS							201 P02 812
C 28/16 ZN	28	16	14	2,5		1,160	201 C02 816
C 28/16 SS							201 P02 816
C 38/18 ZN	38	18	22	2,5		1,430	201 C03 818
C 38/18 SS							201 P03 818
C 30/24 ZN	30	24	20	1,5		0,940	201 C03 024
C 30/24 SS							201 P03 024
C 45/40 ZN	45	40	31	2		2,050	201 C04 540
C 45/40 SS							201 P04 540

ÇELİK PROFİLLER

Technical Drawing
Teknik Çizim

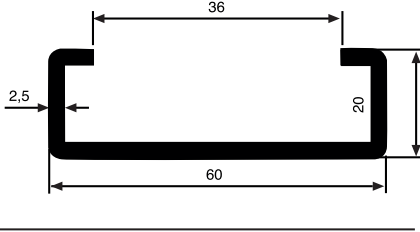

Malzeme/Material
SS: Paslanmaz Çelik/ Stainless Steel
ZN: Çinko/Zinc

L: Standart Uzunluk (metre)/Standart Length (meter)			
Profil Guide	L	Kg/m	Stok Kod Stock Code
ZN	2	2,160	201 C06 020
SS			201 P06 020

ÇELİK PROFİLLER

Technical Drawing
Teknik Çizim

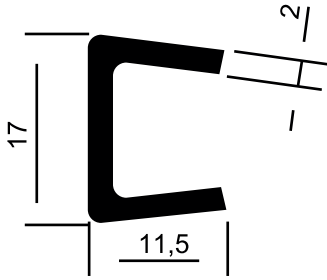

L: Standart Uzunluk (metre)/Standart Length (meter)			
Profil Guide	L	Kg/m	Stok Kod Stock Code
ZN	2	0,468	201 C17 011
SS			201 P17 011

P 1000 YARI MAMUL PLAKALARI

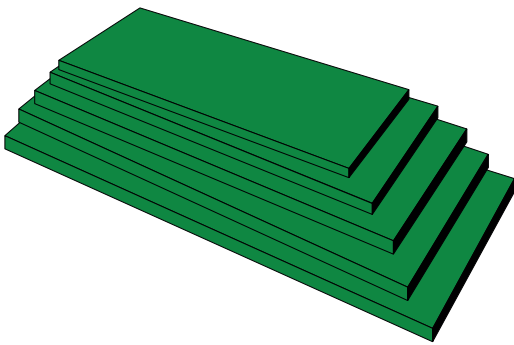

ÖLÇÜLER/DIMENSIONS: 2000 X 1000 mm
KALINLIK/THICKNESS: 2-150 mm
RENKLER/COLOURS:
YEŞİL-SİYAH-BEYAZ/GREEN-BLACK-WHITE

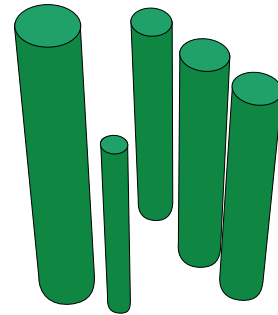

ÖLÇÜLER/DIMENSIONS: Ø20-Ø300 mm
UZUNLUK/LENGTH: 1000 mm
RENKLER/COLOURS:
YEŞİL-SİYAH-BEYAZ/GREEN-BLACK-WHITE

DOĞRUSAL YATAKLAR (863 SERİSİ)

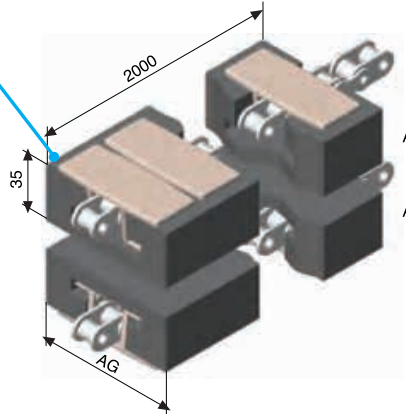
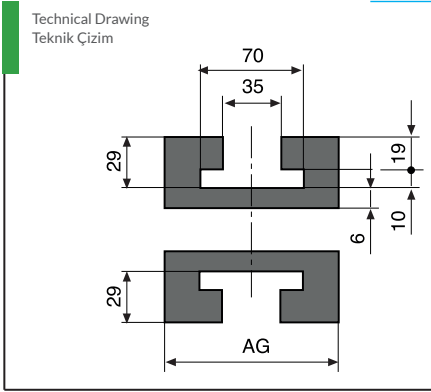

1 SET = GİDİŞ + DÖNÜŞ
1 SET = CARRY + RETURN
1 SET = 4 m



L: Standart Uzunluk (metre)/Standart Length (meter)

	Bant Geniřliđi Chain Width	AG	Stok Kod Stock Code
P 1000 Yeřil/Siyah	82,6	100	203 863 082
	114,3	130	203 863 114
	190,5	200	203 863 190
	254,0	270	203 863 254
	304,8	320	203 863 304

P 1000 DOĐRUSAL YATAKLARI 880-881 BANTLAR İÇİN;

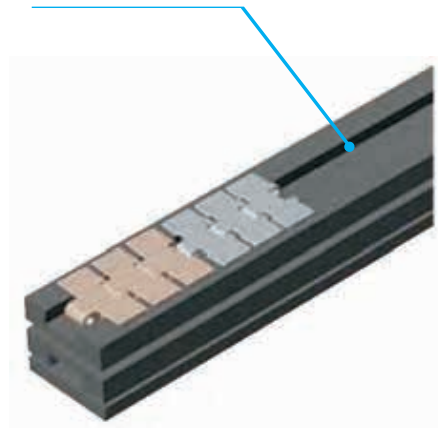
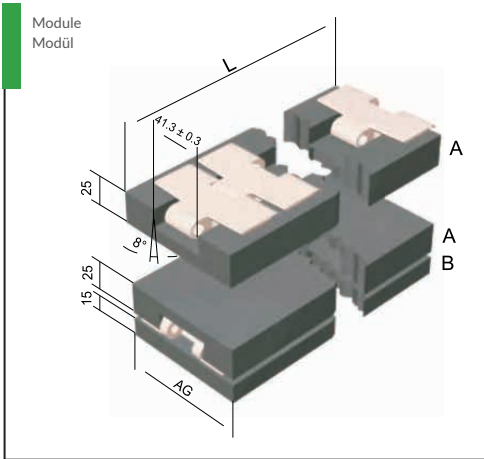

1 Set = Gidiř ve Dönüş (A+A+B)/1 Set = Carry and Return (A+A+B)

L: Standart Uzunluk (metre)/Standart Length (meter)

	Bant Geniřliđi Chain Width	Kg/m	L (m)	Stok Kod Stock Code
P 1000 Siyah	82,6	5,00	2	203 880 082
	114,3	6,90		203 880 114
	190,5	11,35		203 880 190

P 1000 DOĞRUSAL YATAKLARI 880TAB-881TAB BANTLAR İÇİN;

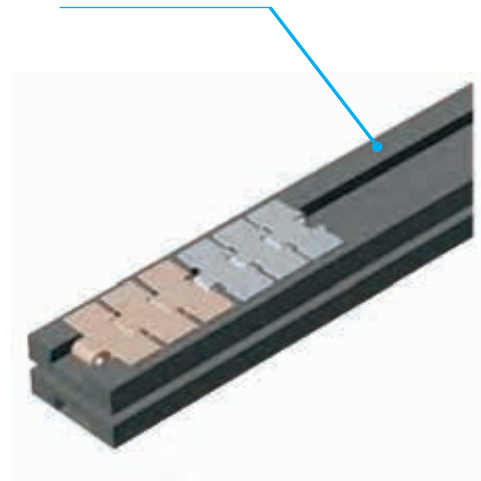
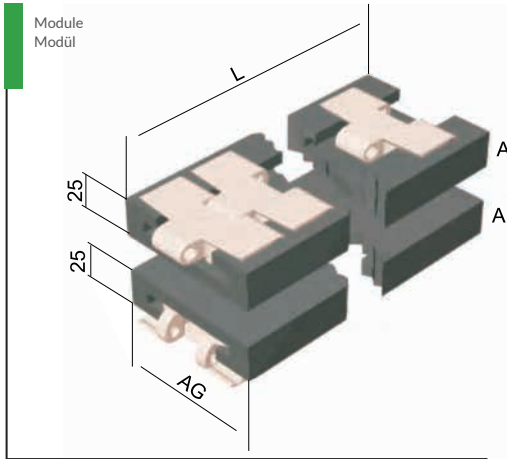

1 Set = Gidiş ve Dönüş (A+A+B)/1 Set = Carry and Return (A+A+B)

L: Standart Uzunluk (metre)/Standart Length (meter)				
	Bant Geniřliđi Chain Width	Kg/m	L (m)	Stok Kod Stock Code
P 1000 Siyah	82,6	2,95	2	203 88T 082
	114,3	4,80		203 88T 114
	190,5	7,80		203 88T 190

P 1000 DOĞRUSAL YATAKLARI AđIR TİP 882 BANTLAR İÇİN;

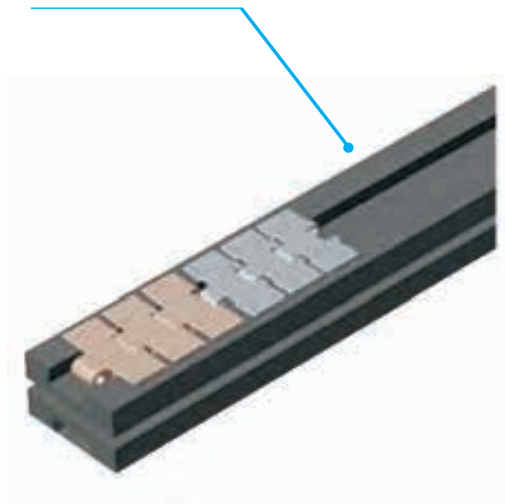
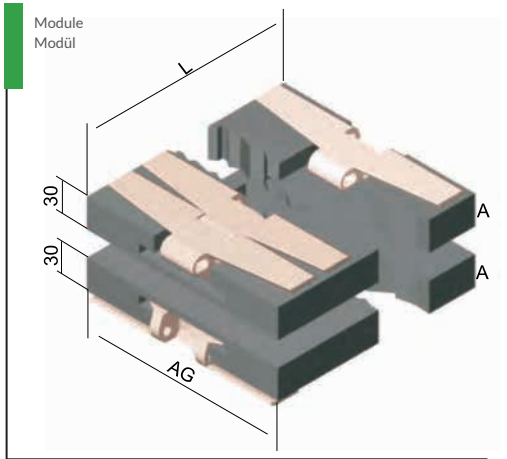

L: Standart Uzunluk (metre)/Standart Length (meter)				
	Bant Geniřliđi Chain Width	Kg/m	L (m)	Stok Kod Stock Code
P 1000 Siyah	190,5	8,65	2	203 882 190
	254,3	12,70		203 882 254
	304,8	15,65		203 882 304

P 1000 90 DERECE(880 TAB-881 TAB DÖNÜŞLÜ BANTLAR İÇİN) DÖNÜŞ YATAKLARI

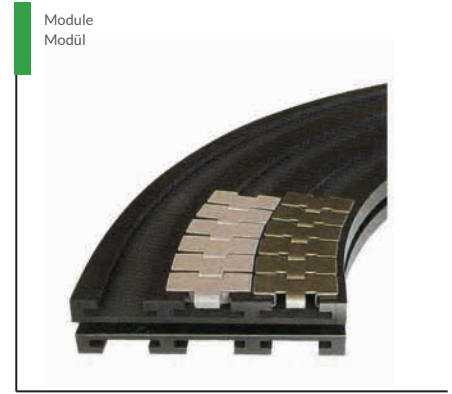
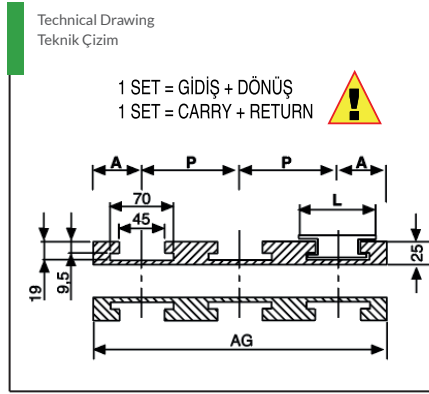
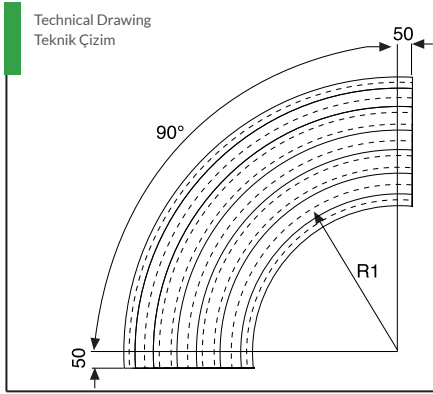

Profil Bölümü/Profiles: "C"		L= 82,6 P= 84 mm			
	R1	A	Sıra Track	L (m)	Stok Kod Stock Code
P 1000 Siyah	500	50	1	100	500 215 182
	500	50	2	184	500 215 282
	500	50	3	268	500 215 382
	500	50	4	352	500 215 482
	500	50	5	436	500 215 582
	500	50	6	520	500 215 682
	610	50	1	100	610 215 182
	610	50	2	184	610 215 282
	610	50	3	268	610 215 382
	610	50	4	352	610 215 482
	610	50	5	436	610 215 582
	610	50	6	520	610 215 682
	800	50	1	100	800 215 182
	800	50	2	184	800 215 282
	800	50	3	268	800 215 382
	800	50	4	352	800 215 482
	800	50	5	436	800 215 582
	800	50	6	520	800 215 682
	1000	50	1	100	100 215 182
	1000	50	2	184	100 215 282
	1000	50	3	268	100 215 382
	1000	50	4	352	100 215 482
	1000	50	5	436	100 215 582
	1000	50	6	520	100 215 682

Profil Bölümü/Profiles: "C"		L= 82,6 P= 85 mm			
	R1	A	Sıra Track	L (m)	Stok Kod Stock Code
P 1000 Siyah	500	50	1	114	501 215 182
	500	50	2	185	501 215 282
	500	50	3	270	501 215 382
	500	50	4	355	501 215 482
	500	50	5	440	501 215 582
	500	50	6	525	501 215 682
	610	50	-	-	611 215 182
	610	50	2	185	611 215 282
	610	50	3	270	611 215 382
	610	50	4	355	611 215 482
	610	50	5	440	611 215 582
	610	50	6	525	611 215 682
	800	50	-	-	801 215 182
	800	50	2	185	801 215 282
	800	50	3	270	801 215 382
	800	50	4	355	801 215 482
	800	50	5	440	801 215 582
	800	50	6	525	801 215 682
	1000	50	-	-	101 215 182
	1000	50	2	185	101 215 282
	1000	50	3	270	101 215 382
	1000	50	4	355	101 215 482
	1000	50	5	440	101 215 582
	1000	50	6	525	101 215 682

Profil Bölümü/Profiles: "C"		L= 82,6 P= 88 mm			
	R1	A	Sıra Track	AG	Stok Kod Stock Code
P 1000 Siyah	500	50	1	-	502 215 182
	500	50	2	188	502 215 282
	500	50	3	276	502 215 382
	500	50	4	364	502 215 482
	500	50	5	452	502 215 582
	500	50	6	540	502 215 682
	610	50	-	-	612 215 182
	610	50	2	188	612 215 282
	610	50	3	276	612 215 382
	610	50	4	364	612 215 482
	610	50	5	452	612 215 582
	610	50	6	540	612 215 682
	800	50	-	-	802 215 182
	800	50	2	188	802 215 282
	800	50	3	276	802 215 382
	800	50	4	364	802 215 482
	800	50	5	452	802 215 582
	800	50	6	540	802 215 682
	1000	50	-	-	101 215 182
	1000	50	2	188	101 215 282
	1000	50	3	276	101 215 382
	1000	50	4	364	101 215 482
	1000	50	5	452	101 215 582
	1000	50	6	540	101 215 682

Profil Bölümü/Profiles: "C"		L= 114,3 P= 120 mm			
	R1	A	Sıra Track	AG	Stok Kod Stock Code
P 1000 Siyah	500	65	1	130	500 215 114
	500	65	2	250	500 215 214
	610	65	1	130	610 215 114
	610	65	2	250	610 215 214
	800	65	1	130	800 215 214
	800	65	2	250	800 215 114
	1000	65	1	130	100 215 114
	1000	65	2	250	100 215 214

/Profiles: "C"		L= 190,5 P= 196 mm			
	R1	A	Sıra Track	AG	Stok Kod Stock Code
P 1000 Siyah	500	100	1	200	500 215 119
	500	100	2	396	500 215 219
	610	100	1	200	610 215 119
	610	100	2	396	610 215 219
	800	100	1	200	800 215 119
	800	100	2	396	800 215 219
	1000	100	1	200	100 215 119
	1000	100	2	396	100 215 219

P 1000 90 DERECE (880 AÇILI KULAKLI BANTLAR İÇİN) DÖNÜŞ YATAKLARI



1 SET = GİDİŞ + DÖNÜŞ
1 SET = CARRY + RETURN



Profil Bölümü/Profiles: "C"		L= 82,6 P= 90 mm			
	R1	A	Sıra Track	AG	Stok Kod Stock Code
P 1000 Siyah	500	50	1	100	500 205 182
	500	50	2	190	500 205 282
	500	50	3	280	500 205 382
	500	50	4	370	500 205 482
	610	50	1	100	610 205 082
	650	50	1	100	650 205 182
	650	50	2	190	650 205 282
	650	50	3	280	650 205 382
	650	50	4	370	650 205 482
	860	50	1	100	860 205 281
	860	50	2	190	860 205 282
	860	50	3	280	860 205 283
860	50	4	370	860 205 284	

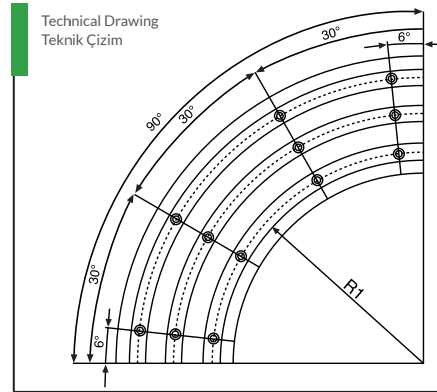

Profil Bölümü/Profiles: "C"		L= 114,3 P= 125 mm			
	R1	A	Sıra Track	AG	Stok Kod Stock Code
P 1000 Siyah	550	65	1	130	550 205 114
	550	65	2	255	550 205 214
	550	65	3	380	550 205 314
	550	65	4	505	550 205 414
	610	65	1	130	610 205 114
	650	65	1	130	650 205 114
	650	65	2	255	650 205 214
	650	65	3	380	650 205 314
	650	65	4	505	650 205 414

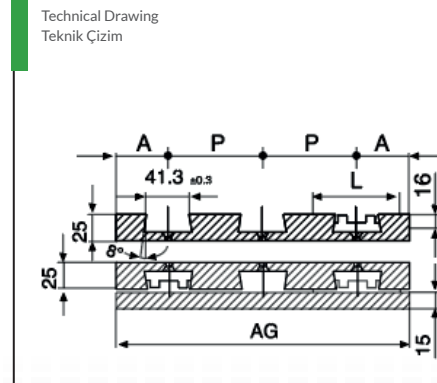

Profil Bölümü/Profiles: "C"		L= 114,3 P= 125 mm			
	R1	A	Sıra Track	AG	Stok Kod Stock Code
P 1000 Siyah	610	100	1	200	610 205 119
	650	100	1	200	650 205 119

P 1000 90 DERECE DÖNÜŞ YATAKLARI (882 TAB DÖNÜŞLÜ AĞIR TİP BANTLAR İÇİN)

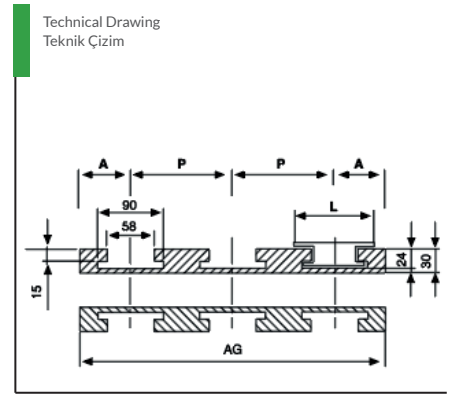
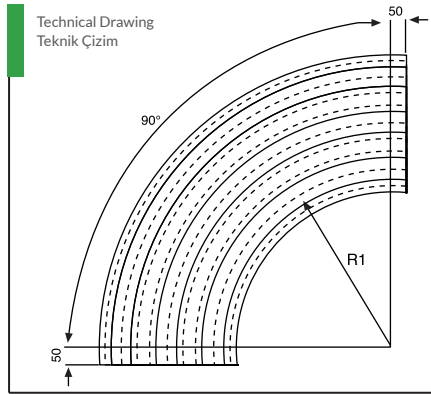

1 SET = GİDİŞ + DÖNÜŞ
1 SET = CARRY + RETURN



Profil Bölümü/Profiles: "C"		L= 114,3 P= 120 mm			
	R1	A	Sıra Track	AG	Stok Kod Stock Code
P 1000 Siyah	610	65	1	130	610 215 114
	610	65	2	250	610 215 214
	800	65	1	130	800 215 114
	800	65	2	250	800 215 214
	1000	65	1	130	100 215 114
	1000	65	2	250	100 215 214
	1200	65	1	130	120 215 114
	1200	65	2	250	120 215 214

Profil Bölümü/Profiles: "C"		L= 190,5 P= 196 mm			
	R1	A	Sıra Track	AG	Stok Kod Stock Code
P 1000 Siyah	610	100	1	200	610 220 119
	610	100	2	396	610 220 219
	800	100	1	200	800 220 119
	800	100	2	396	800 220 219
	1000	100	1	200	100 220 119
	1000	100	2	396	100 220 219
	1200	100	1	200	120 220 119
	1200	100	2	396	120 220 219

Profil Bölümü/Profiles: "C"		L= 1254 P= 260 mm			
	R1	A	Sıra Track	AG	Stok Kod Stock Code
P 1000 Siyah	610	135	1	270	610 220 125
	610	135	2	530	610 220 225
	800	135	1	270	800 220 125
	800	135	2	530	800 220 225
	1000	135	1	270	100 220 125
	1000	135	2	530	100 220 225
	1200	135	1	270	120 220 125
	1200	135	2	530	120 220 225

Profil Bölümü/Profiles: "C"		L= 304,8 P= 310 mm			
	R1	A	Sıra Track	AG	Stok Kod Stock Code
P 1000 Siyah	610	160	1	320	610 220 130
	610	160	2	630	610 220 230
	800	160	1	320	800 220 130
	800	160	2	630	800 220 230
	810	170	1	340	810 220 130
	1000	160	1	320	100 220 130
	1000	160	2	630	100 220 230
	1160	170	1	340	116 220 130
	1200	160	1	320	100 220 130
	1200	160	2	630	100 220 230

Zincir Kızakları Grubu

OMURGALI (KARDENİK) BANT DÖNÜŞ TAKIMI

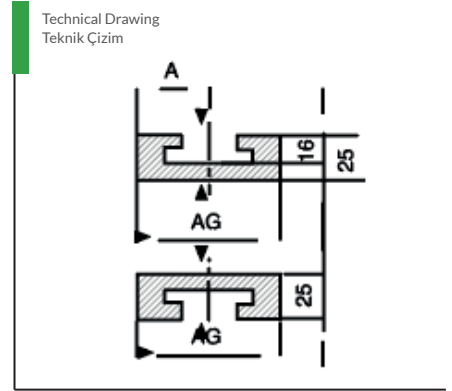
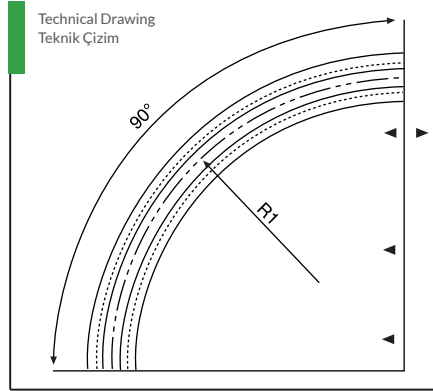

1 SET = GİDİŞ + DÖNÜŞ
1 SET = CARRY + RETURN



Profil Bölümü/Profiles: "C"		L: Standart Uzunluk (metre)/Standart Length (meter)				
		R1	R2	R3	AG	Stok Kod Stock Code
P 1000 Siyah	865	150	-	-	80	150 225 082
			215	-	145	150 225 182
			280	210	150 225 282	
		250	-	-	80	250 225 082
		500	-	-	80	500 225 082
		630	-	-	80	630 225 082

Profil Bölümü/Profiles: "C"		L: Standart Uzunluk (metre)/Standart Length (meter)				
		R1	R2	R3	AG	Stok Kod Stock Code
P 1000 Siyah	860	150	-	-	80	150 226 082
						500 226 182

KASA TAŞIMA BANT KIZAKLARI

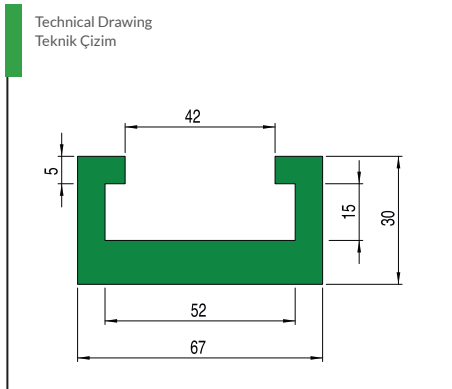
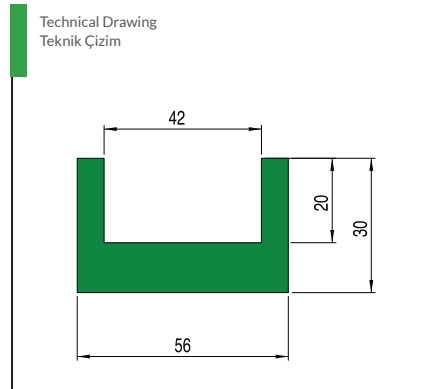

230 KSK 857

230 KSK 858

Profil Bölümü/Profiles: "C"		L: Standart Uzunluk (metre)/Standart Length (meter)			
	Kullanılan Bantlar For chains	R2	Kg/m	Stok Kod Stock Code	
P 1000 Siyah	857	2	0,65	230 KSK 857	
	858		0,30	230 KSK 858	

Zincir Kızakları Grubu

YARASA BANT DÖNÜŞ ÜNİTESİ

Module
Modül



Technical Drawing
Teknik Çizim

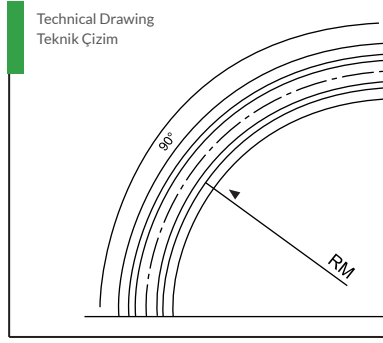

Technical Drawing
Teknik Çizim

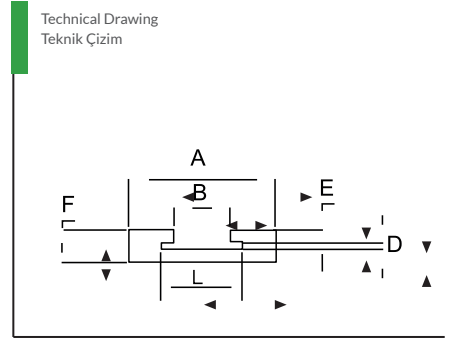

1 SET = GİDİŞ + DÖNÜŞ
1 SET = CARRY + RETURN



	A	B	L	D	E	F	RM	Kg/m	Stok Kod Stock Code
P 1000 Siyah	100	43	63	5	10,5	20	250	0,160	112 204 610

YARASA BANT DÖNÜŞ ÜNİTESİ (SİLİNDİRİK KULAKLILAR İÇİN)

Module
Modül

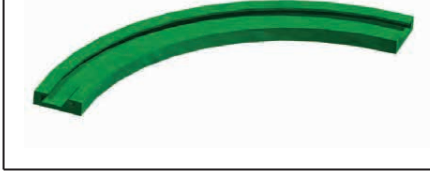

Technical Drawing
Teknik Çizim

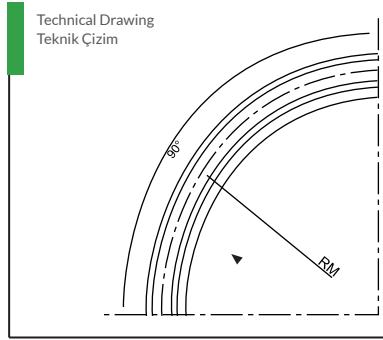

Technical Drawing
Teknik Çizim

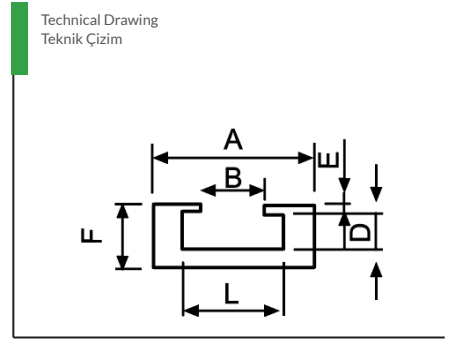

1 SET = GİDİŞ + DÖNÜŞ
1 SET = CARRY + RETURN



	A	B	L	D	E	F	RM	Kg/m	Stok Kod Stock Code
P 1000 Siyah	114	49,4	79,4	18,4	5	30	250	0,170	114 204 610

Module
Modül



Technical Drawing
Teknik Çizim

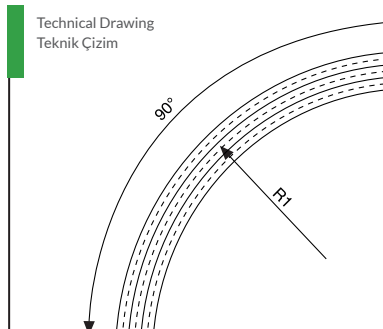

Technical Drawing
Teknik Çizim

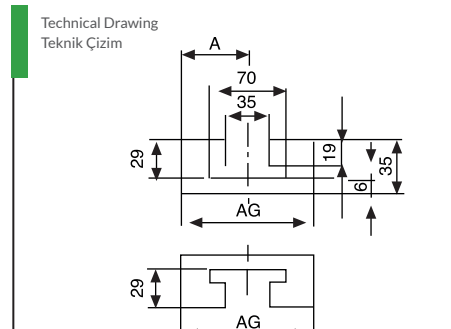









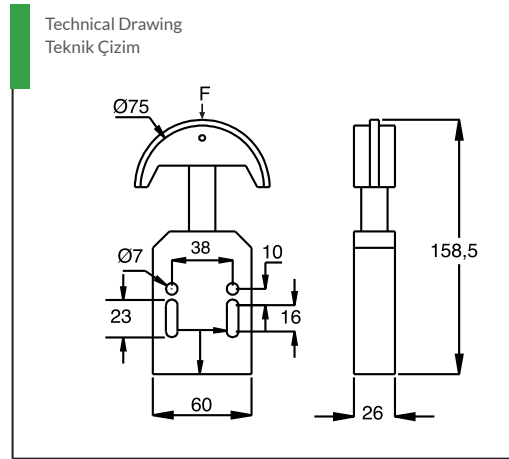

Profil Bölümü/Profiles: "C"

L= 304,8 P= 310 mm









	R1	A	Sıra Track	AG	Stok Kod Stock Code
P 1000 Siyah	610	82,5	50	320	611 221 873
	800	82,5	50	630	801 221 873
	610	114,3	65	320	611 222 873
	800	114,3	65	630	801 222 873
	610	190,5	100	340	611 223 873
	800	190,5	100	320	801 223 873
	610	254,0	135	630	611 224 873
	800	254,0	135	340	801 224 873
	610	304,8	160	320	611 220 873
	800	304,8	160	630	801 220 873

PNÖMATİK ZİNCİR GERGİSİ



Profil Bölümü/Profiles: "C"		L: Standart Uzunluk (metre)/Standart Length (meter)			
	Hatve Pitch	Profil Guide	F Baskı Kuvveti Tension Pressure (N)	Stok Kod Stock Code	
P 1000 Kırmızı/Red	 3/8"	1	60	200 GKR 138	
P 1000 Kırmızı/Red	 1/2"	1	60	200 GKR 112	
P 1000 Kırmızı/Red	 5/8"	1	60	200 GKR 158	
P 1000 Kırmızı/Red	 3/4"	1	120	200 GKR 134	
P 1000 Kırmızı/Red	 1"	1	200	200 GKR 101	
P 1000 Yeşil/Green	 3/8"	1	60	200 GYR 138	
P 1000 Yeşil/Green	 1/2"	1	60	200 GYR 112	
P 1000 Yeşil/Green	 5/8"	1	60	200 GYR 158	
P 1000 Yeşil/Green	 3/4"	1	120	200 GYR 134	
P 1000 Yeşil/Green	 1"	1	200	200 GYR 101	

PNÖMATİK ZİNCİR GERGİSİ

Profil Bölümü/Profiles: "C"		L: Standart Uzunluk (metre)/Standart Length (meter)			
	A	Profil Guide	F Baskı Kuvveti Tension Pressure (N)	Stok Kod Stock Code	
P 1000 Kırmızı/Red	 3/8"	2	60	200 GKR 208	
P 1000 Kırmızı/Red	 1/2"	2	60	200 GKR 212	
P 1000 Kırmızı/Red	 5/8"	2	60	200 GKR 258	
P 1000 Kırmızı/Red	 3/4"	2	120	200 GKR 234	
P 1000 Yeşil/Green	 3/8"	2	60	200 GYR 208	
P 1000 Yeşil/Green	 1/2"	2	60	200 GYR 212	
P 1000 Yeşil/Green	 5/8"	2	60	200 GYR 258	
P 1000 Yeşil/Green	 3/4"	2	120	200 GYR 234	

*LÜTFEN ÖZEL ÖLÇÜLERİ TALEP EDİNİZ./TO MAKE AN ORDER INDICATE DIMENSIONS.



RULMAN
GRUBU

RULMAN ÇEŞİTLERİ



- ✓ Lineer raylı sistemler ve rulmanları
- ✓ İğneli rulmanlar
- ✓ Yataklı rulmanlar (Döküm)
- ✓ Yataklı rulmanlar (Sac)
- ✓ Yataklı rulmanlar
(Plastik yatak paslanmaz rulman)
- ✓ Yataklı rulmanlar (Komple paslanmaz)
- ✓ Oynak makaralı rulmanlar
- ✓ SL serisi
- ✓ Konik makaralı rulmanlar
- ✓ Eksenel sabit bilyalı rulmanlar
- ✓ 1000-2000 serisi
- ✓ 7200-7300 serisi
- ✓ CSK serisi
- ✓ Minyatür rulmanlar
- ✓ Paslanmaz rulmanlar
- ✓ Seramik rulmanlar
- ✓ Sabit bilyalı rulmanlar
- ✓ 6000-6200-6300 serisi





- ✓ Kastaş
- ✓ Pnömatik
- ✓ Keçeler
- ✓ O-Ring
- ✓ Sızdırmazlık Grubu





Triger Dişliler

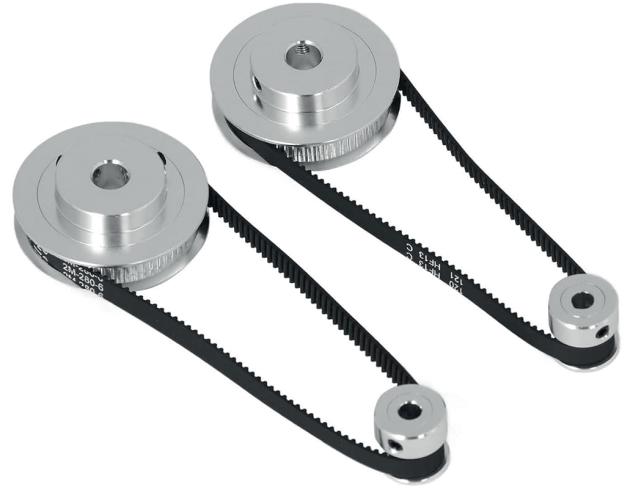

Zincir Dişliler

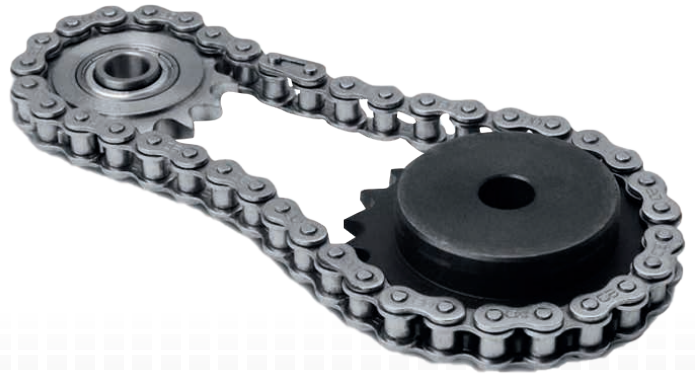

V Kasnak -Kör Kasnak Grubu

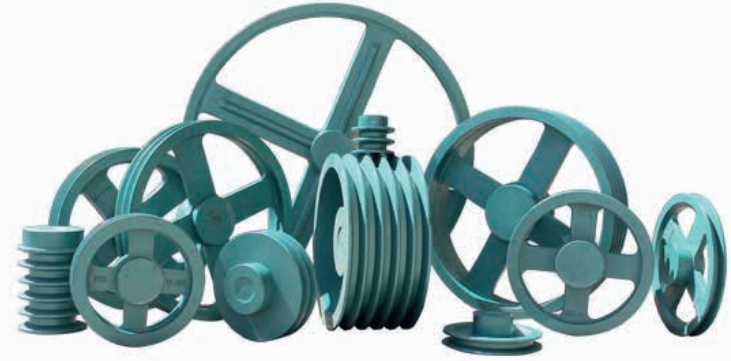

Kaplin Grubu

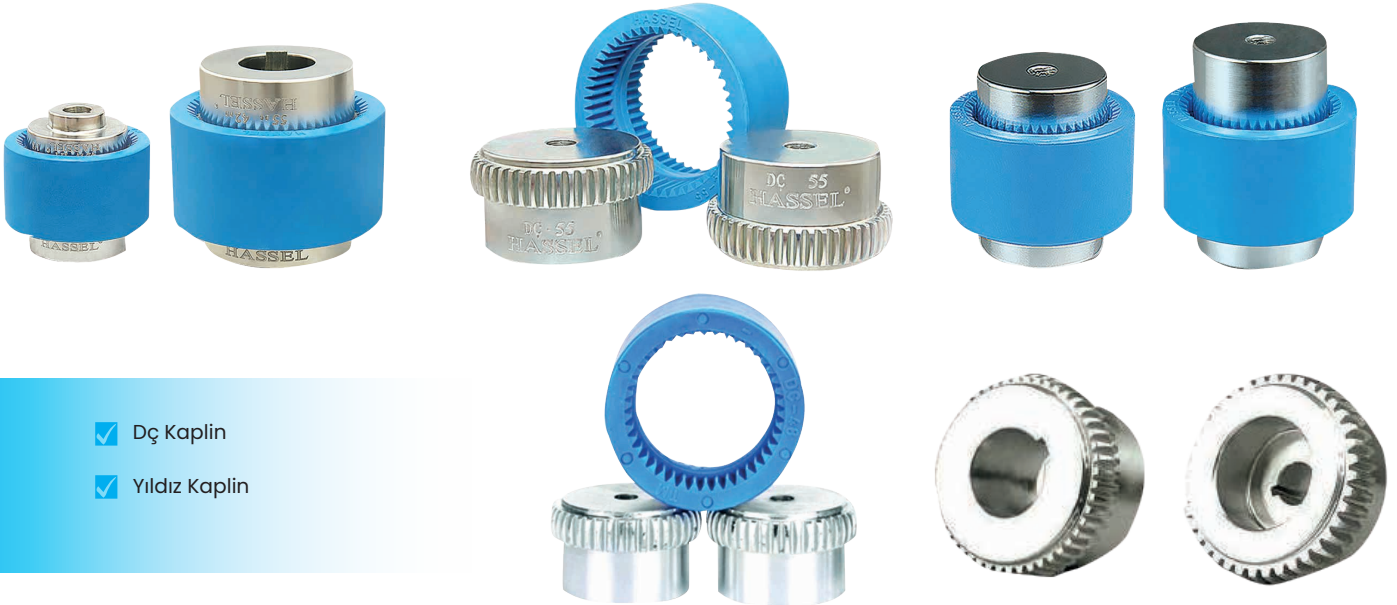

- Dç Kaplin
- Yıldız Kaplin

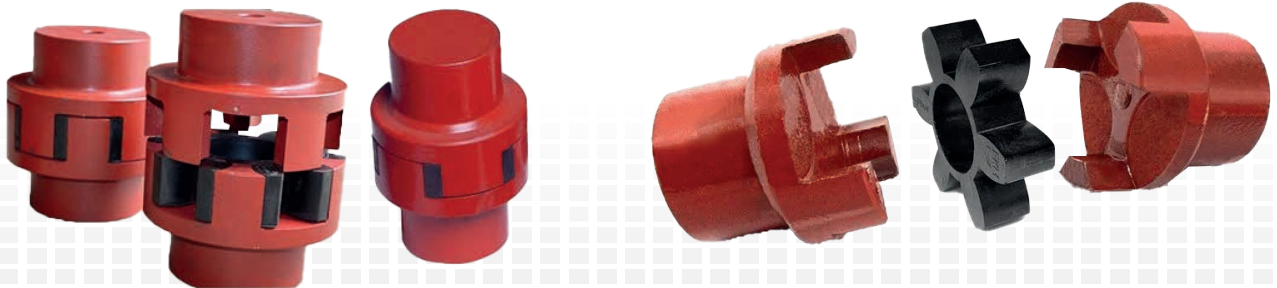

Zincir Grubu

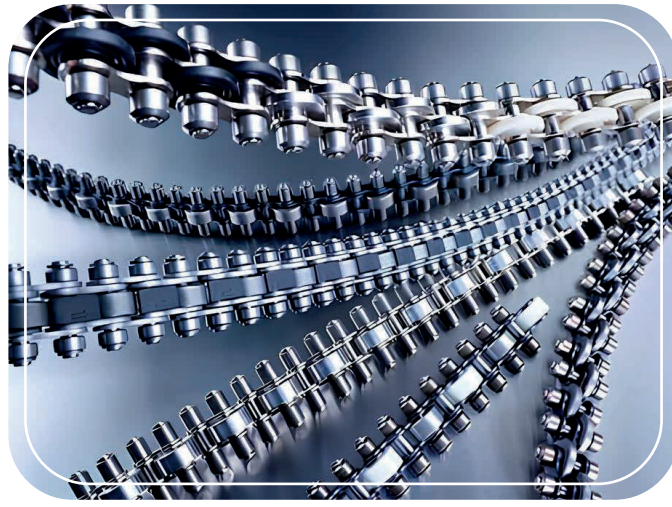
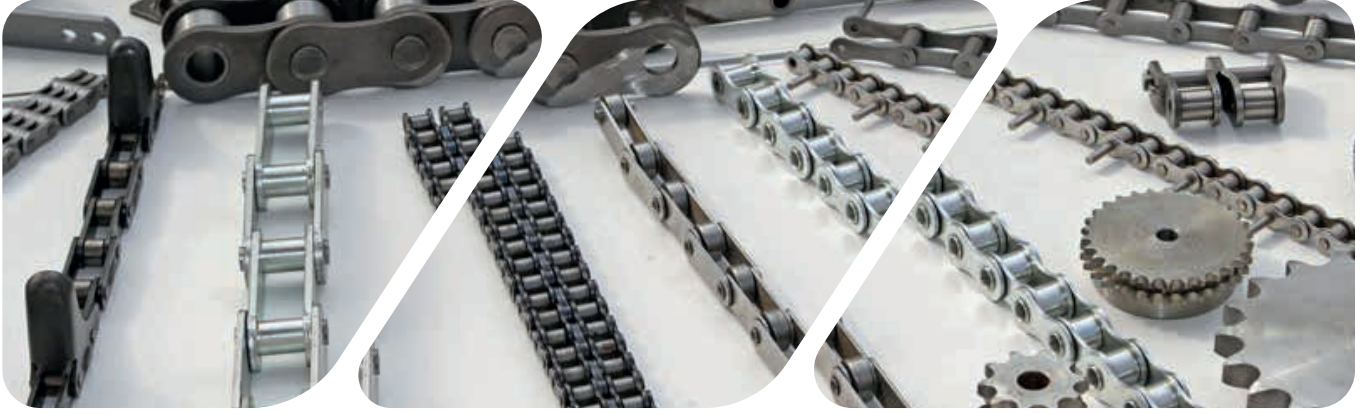

Kayış Grubu



Pnömatik Grubu

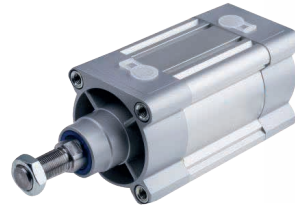

- Pnömatik Piston ✓
- Bağlantı Grubu ✓
- Şartlandırıcı ✓
- Piston ✓
- Valf ✓
- Pnömatik Hortum ✓

Teker Grubu



El Aletleri Grubu



Elektrikli El Aletleri Grubu



Mühendislik Plastikleri

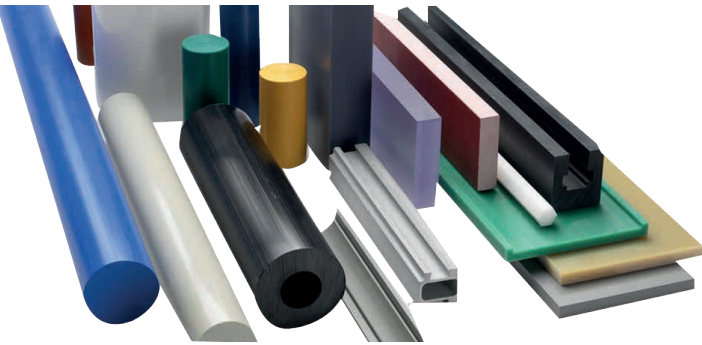
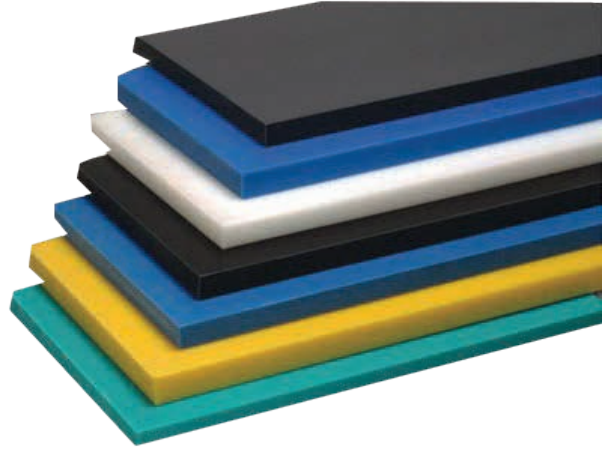

- Pom ✓
- Döküm Polyamit ✓
- Teflon ✓
- Polyamid ✓
- Polipropilen ✓
- PTFE ✓

Metal Grubu



- Krom Kaplı Mil ✓
- İndüksiyonlu Mil ✓
- Civa Çeliği ✓
- Pirinç Sarı ✓
- Bronz ✓

Tezgah Tamponu Ve Bakalit Grubu



Zenweld Kaynak Makinası



Lazer Kaynak Makinası



İş Güvenliği Grubu

- *AYAKKABI
- *ELDİVEN
- *BARET
- *TOZ MASKELERİ
- *EMNİYET KEMERLERİ
- *HALAT EKİPMANLARI



RULMEK
HIRDAVAT VE MEKATRONİK

SAN.DIŐ TİC LTD.ŐTİ



rulmek 
RULMAN MEKATRONİK HIRDAVAT SAN. VE DIŐ TİC. LTD. ŐTİ.



0 (338) 212 00 88
0 (545) 920 19 86



Merkez:
Hamidiye Mahallesi Sanayi Cad.No:61 - 63 Merkez/KARAMAN



Fabrika:
Organize Sanayi Bölgesi 3. Cadde No:35 Merkez/KARAMAN



www.rulmek.com



info@rulmek.com.tr
satis@rulmek.com.tr



[linkedin.com/in/rulmek2017](https://www.linkedin.com/in/rulmek2017)



@rulmek_